

61579

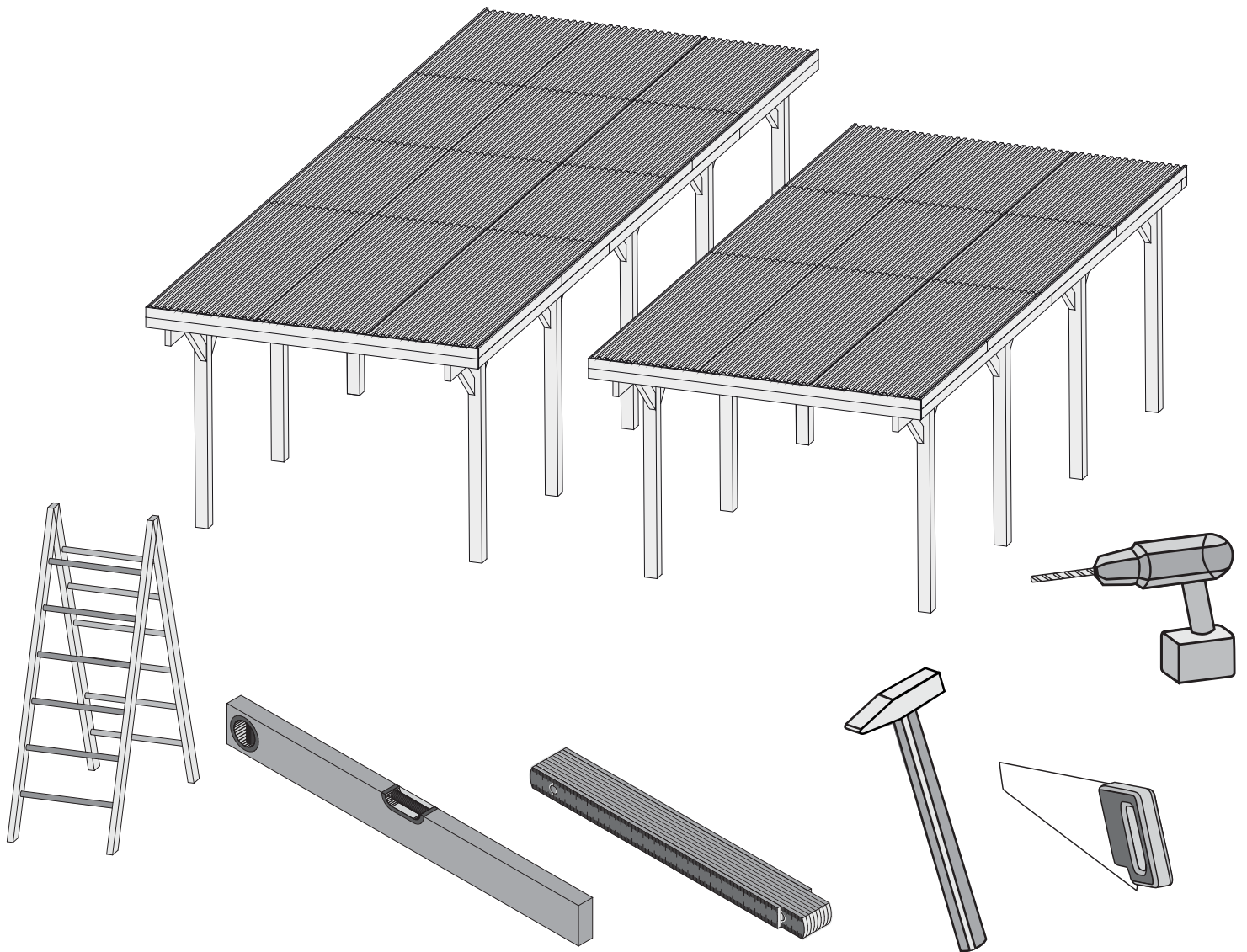

 **Aufbauanleitung**

 **notice de montage**

 **Building Instructions**

 **montagehandleiding**

 **Instrucciones de construcción**

 **Istruzioni per il montaggio**

 **Montážní návod**



Vergleichen Sie zuerst die Materialliste mit Ihrem Paketinhalt! Bitte haben Sie Verständnis, dass Beanstandungen nur im nicht aufgebauten Zustand bearbeitet werden können!



En primer lugar, compare la lista de material con el contenido del paquete. Rogamos entienda que las reclamaciones sólo pueden ser tramitadas antes de montar el objeto!



Nejprve přezkontrolujte obsah balení podle materiálového listu! Mějte pochopení pro to, že případnou reklamaci se můžeme zabývat pouze tehdy, když díly nebudou smontované! Za pomoci tohoto seznamu můžete jednotlivé díly přiřadit k montážnímu návodu.



Vergelijk eerst de lijst van materialen met de inhoud van uw pakket! Reclamaties kunnen alleen in behandeling worden genomen zolang de onderdelen nog niet zijn gemonteerd!



First compare the list of materials with your package contents! Please understand that complaints can be processed in the non-built status only!



Commencez par comparer la liste du matériel avec le contenu de votre paquet! Sachez que nous traitons uniquement les réclamations concernant le matériel à l'état non monté!



Confrontate questa distinta materiali prima con il contenuto del pacchetto! Vi preghiamo di comprendere che eventuali reclami possono essere accolti solo prima del montaggio!

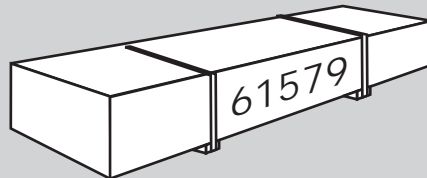

2 x B2	3300 x 95 x 18mm	ID 51821
1 x B3	3140 x 60 x 40mm	ID 40805
2 x B4	3140 x 155 x 55mm	ID 62575

4 x C1	750 x 115 x 55mm	ID 16478

60 x		ID 73734
------	--	----------

2 x U3	2100 x 120 x 120mm	ID 40629

3 x D1	2000 x 1090 x 18mm	ID 61408

4 x		ID 12011
-----	--	----------

2 x		ID 9253
-----	--	---------

2 x U4	2190 x 155 x 55mm	ID 40627

40 x	4 x 50mm	ID 3688
8 x	4,5 x 80mm	ID 9204
8 x	6 x 160mm	ID 9252

3m		ID 73799
----	--	----------

4 x		ID 21292
-----	--	----------

60 x		ID 73735
------	--	----------

2 x		ID 40787
-----	--	----------

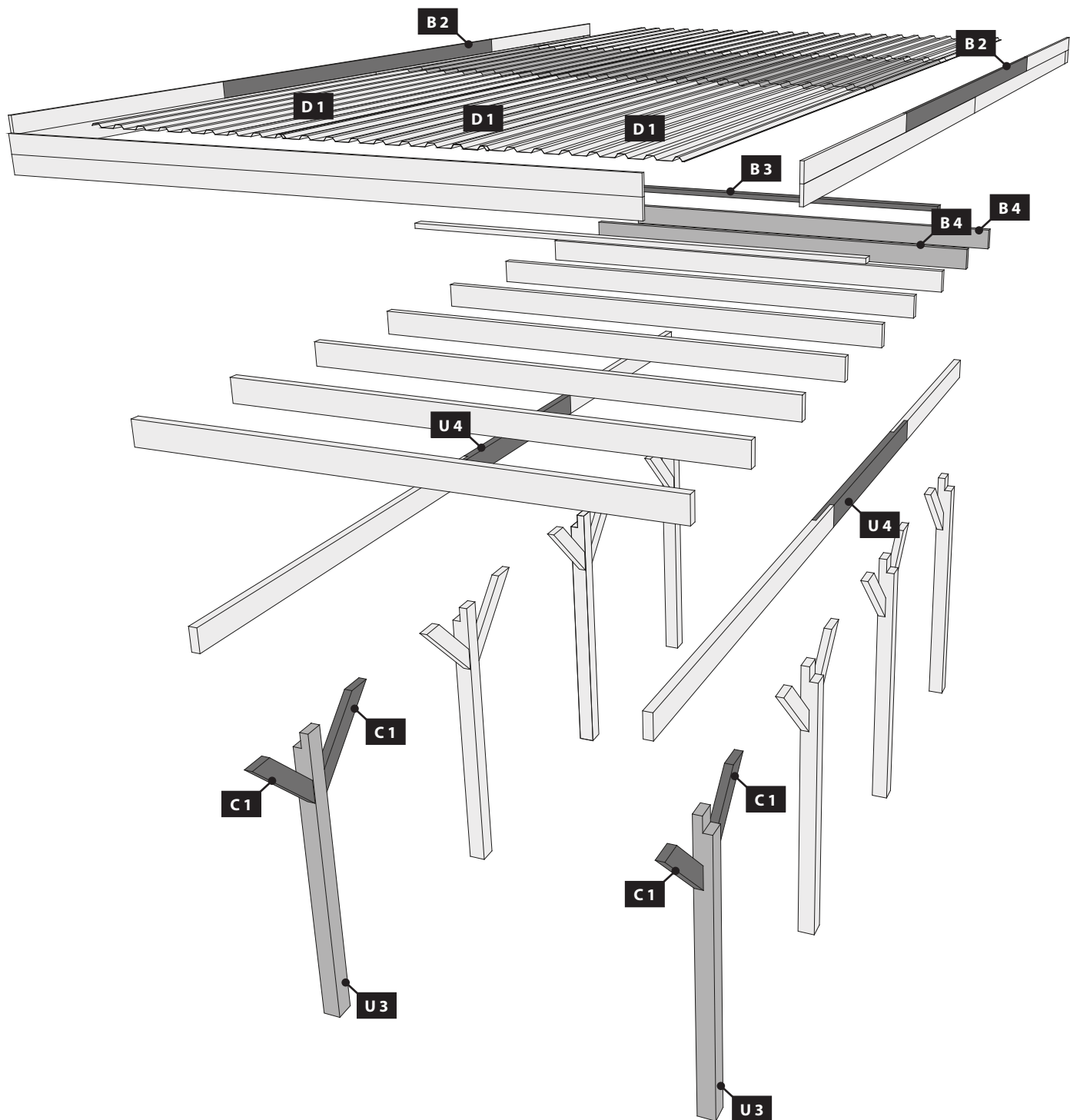



 Die Pfosten dieses Produkts sollten fest mit dem Untergrund verbunden werden. Dazu empfehlen wir H-Pfostenanker. Diese sollten erst nach dem Aufbau dieses Produkts endgültig mit Beton versehen werden. Die H-Pfostenanker und das zugehörige Befestigungsmaterial sind nicht im Lieferumfang dieses Produkts enthalten.

 Les poteaux de cet article doivent être fixés au sol. A cet effet, nous vous recommandons les systèmes d'ancrage en H (accessoires non fournis avec le produit). Ceux-ci doivent être scellés avec du béton une fois la construction du produit terminée.

 The posts of this product should be firmly connected to the ground. We recommend H-post anchors. These should only be finally provided with concrete after the construction of this product. The H-post anchors and associated fasteners are not included with this product.

 De berichten van dit product moet op de grond vastgemaakt. Wij bevelen ook het H-bericht ankers. Deze dienen echter pas na de uiteindelijke structuur van het product met beton worden. De H-paal ankers en de bijbehorende bevestigingsmaterialen worden niet meegeleverd met dit product.

 Los mensajes de este producto debe fijarse al suelo. También te recomendamos anclas H-post. Estos deben ser proporcionados sólo después de la estructura final del producto de hormigón. Los anclajes H-correos y los materiales de fijación asociados no están incluidos con este producto.

 I messaggi di questo prodotto devono essere fissati al suolo. Noi raccomandiamo anche ancore H-post. Questi dovrebbero essere forniti solo dopo che la struttura finale del prodotto con calcestruzzo. Le ancore H-post ed i materiali di fissaggio associati non sono inclusi con questo prodotto.

 Sloupky tohoto produktu by měla být stanovena na zem. Doporučujeme také H-post kotvy. Ty by měly být poskytnuty pouze po konečnou strukturu výrobku s betonem. H-post kotvy a příslušné upevňovací materiály nejsou součástí tohoto produktu.



 Dieses Produkt gibt es in verschiedenen Aufbauvarianten. Sie haben 2-3 Pakete erhalten. Die Stückzahl- und Materialkontrolle sollte immer mit der dem Paket beigefügten Materialliste durchgeführt werden.

Folgender Tabelle können Sie entnehmen, welche Anleitungsschritte mit welcher Nummer Sie zum Aufbau benutzen müssen. Orientieren Sie sich an der Anzahl der gelieferten Pakete und den Artikelnummern auf den Paketen.

 Dit product is er in verschillende opbouwvarianten. U hebt 2-3 pakketten ontvangen. Het aantal stuks en de materiaalcontrole moet altijd met de bij het pakket gevoegde materiaalijst worden uitgevoerd.

In de volgende tabel kunt u zien welke instructiestappen met welk nummer u voor het opbouwen moet volgen. Oriënteer u aan het aantal geleverde pakketten en aan de artikelnummers op de pakketten.

 Ce produit existe dans différentes variantes de montage. Vous avez reçu 2-3 paquets. Le contrôle du nombre de pièces et du matériel doit toujours être effectué à l'aide de la liste du matériel jointe au paquet.

Le tableau suivant vous indique quelles étapes de la notice avec quel numéro vous devez utiliser pour le montage. Veuillez vous orienter sur le nombre de paquets livrés et sur les numéros d'articles figurant sur les paquets.

 Existen distintas variantes de combinaciones de construcción de este producto. Ha recibido de 2 a 3 paquetes. El control de la cantidad y del material siempre debería ser realizado con la lista del material adjunta al paquete.

En la tabla siguiente puede obtener la información del número que debe utilizar con cada etapa de las instrucciones para la construcción. Oriéntese mediante el número de paquetes suministrados y los números de artículos sobre estos.

 This product is available in different construction variants. You have received 2-3 packages. Always control the numbers and materials on the basis of the material list included with the package.

The following table shows which instruction corresponds to which number during assembly of the construction. Construction is oriented to the number of packages supplied and the article numbers shown on the packages.

 Questo prodotto è disponibile in diverse varianti. La consegna può consistere in un numero di pacchi che può variare da 2 a 3. Il controllo del numero di pezzi e del materiale va eseguito sempre con la distinta dei materiali allegata al pacchetto.

Dalla seguente tabella si può dedurre quali istruzioni per l'uso (indicate con i relativi codici) si devono utilizzare per il montaggio. Ci si può orientare basandosi sul numero di pacchetti consegnati e sul codice articolo riportato sui pacchetti stessi.

 Tento produkt je k dispozici v různých tělesných variantách. Obdrželi jste 2-3 balíčky. Počítat kus a kontrolní materiál by měl být vždy provedeno s dokumenty přiloženými k seznamu obalový materiál.

Následující tabulka ukazuje, které ruční kroky, které číslo je nutné použít stavět. Orientovat se na počtu balíků dodaných a čísla článků na obalech.

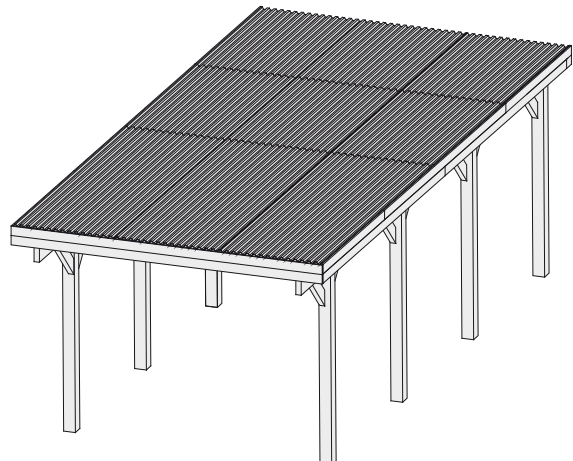
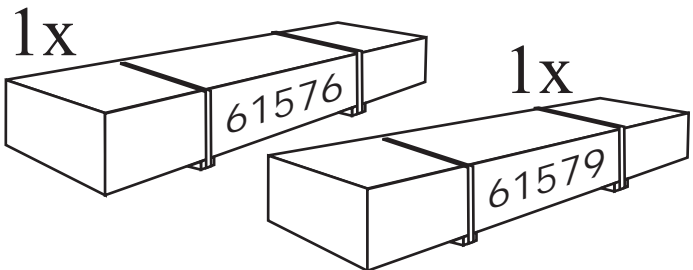

61579 16.10.2015

-  Aufbauanleitung
-  notice de montage
-  Building Instructions
-  montagehandleiding
-  Instrucciones de construcción
-  Istruzioni per il montaggio
-  Montážní návod
-  Service-Hotline: +49 421 38693 33

01 → **26**

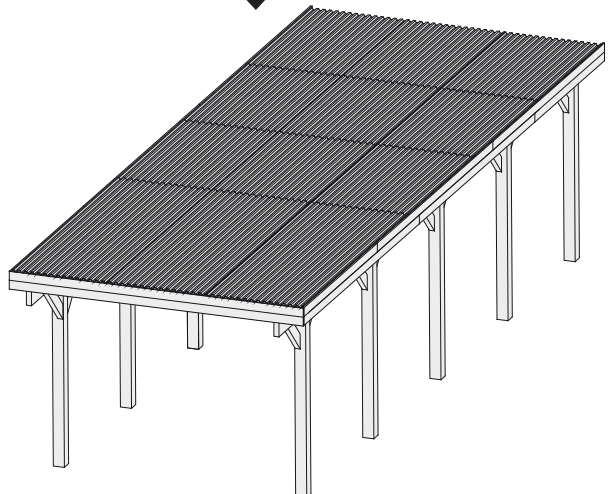
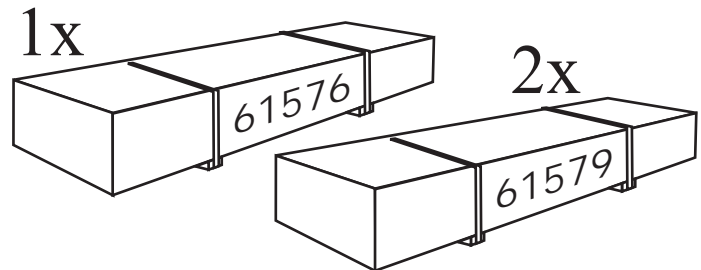

61579 16.10.2015

-  Aufbauanleitung
-  notice de montage
-  Building Instructions
-  montagehandleiding
-  Instrucciones de construcción
-  Istruzioni per il montaggio
-  Montážní návod
-  Service-Hotline: +49 421 38693 33

27 → **52**

01 2x

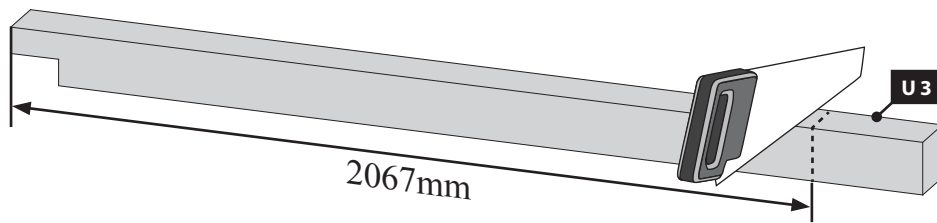

02 2x

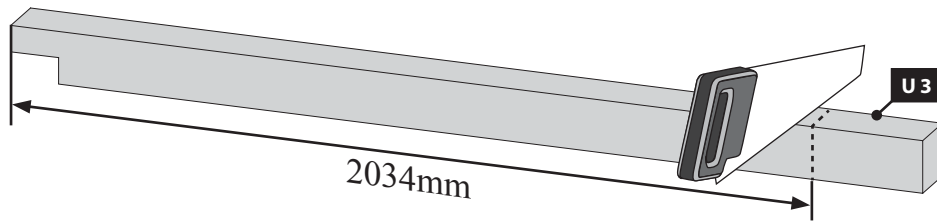



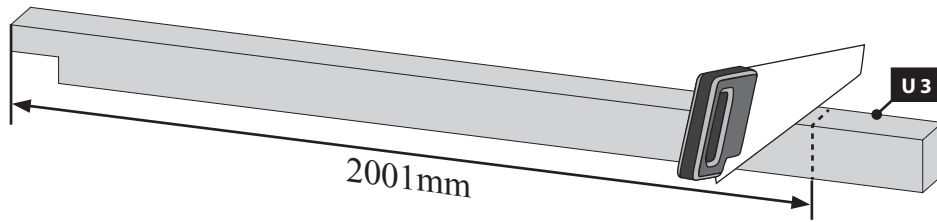

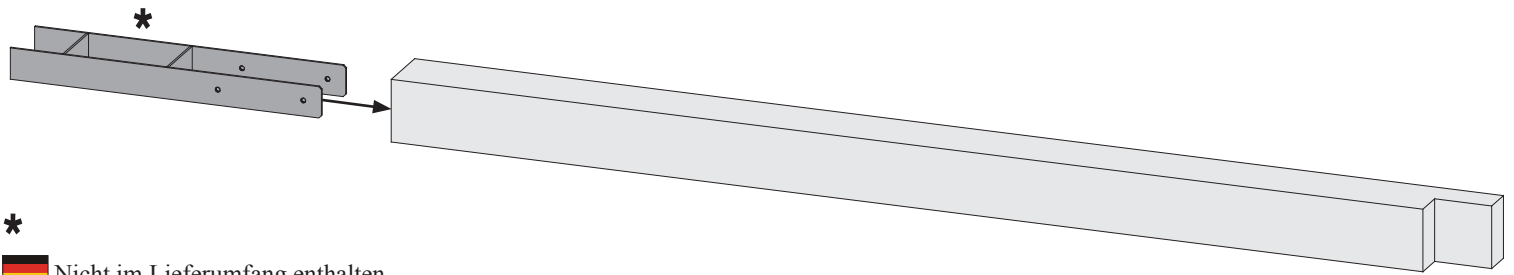

03 2x



04 8x



- *
-  Nicht im Lieferumfang enthalten
 -  Niet bijgeleverd
 -  Not included
 -  Non comprises dans la livraison
 -  No forman parte del suministro
 -  Non incluso
 -  V ceně není zahrnuto

05 8x

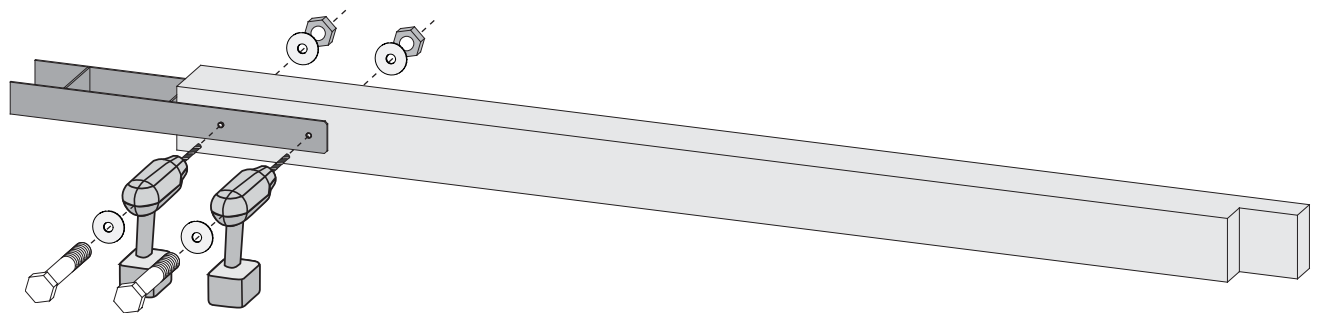

06 2x

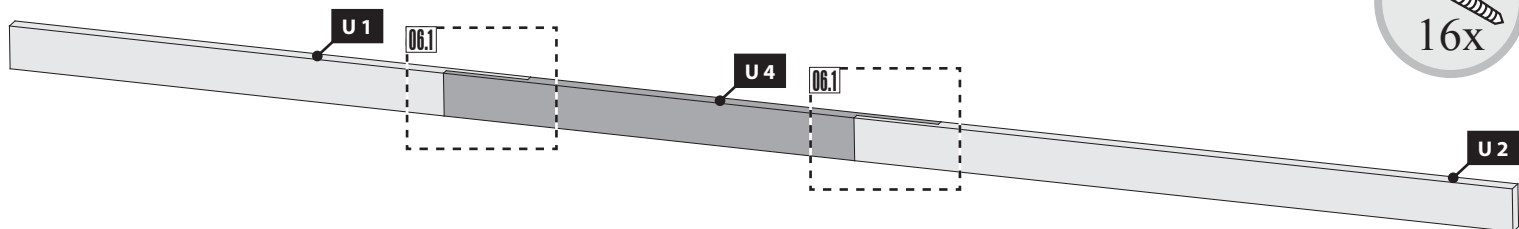

06.1

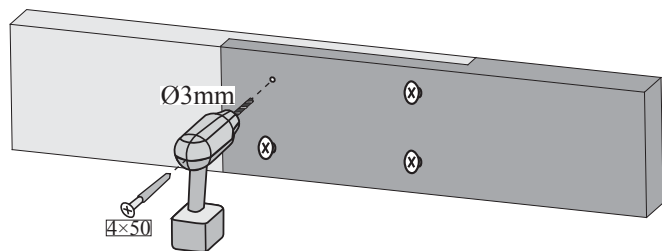

07

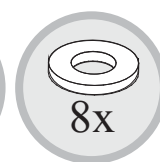
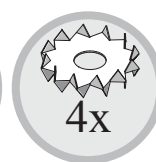
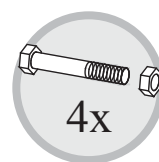
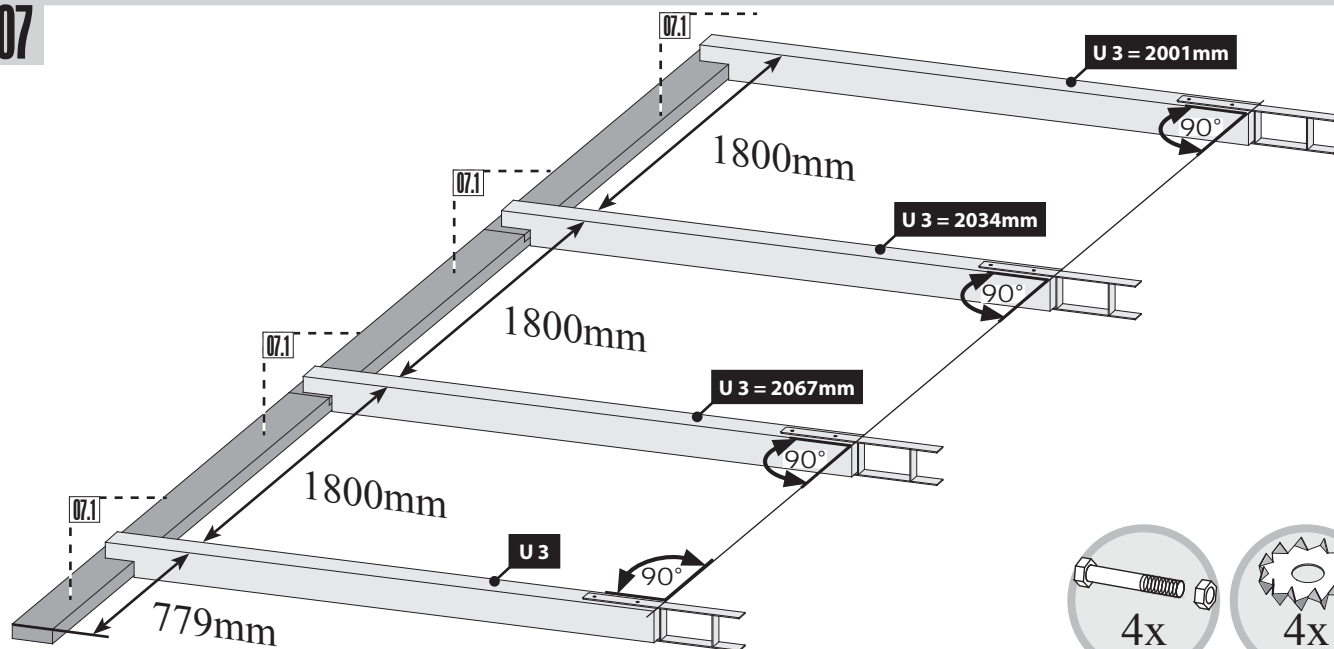

08

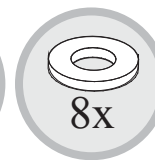
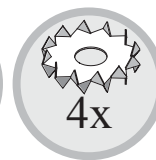
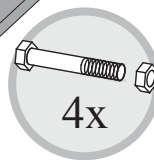
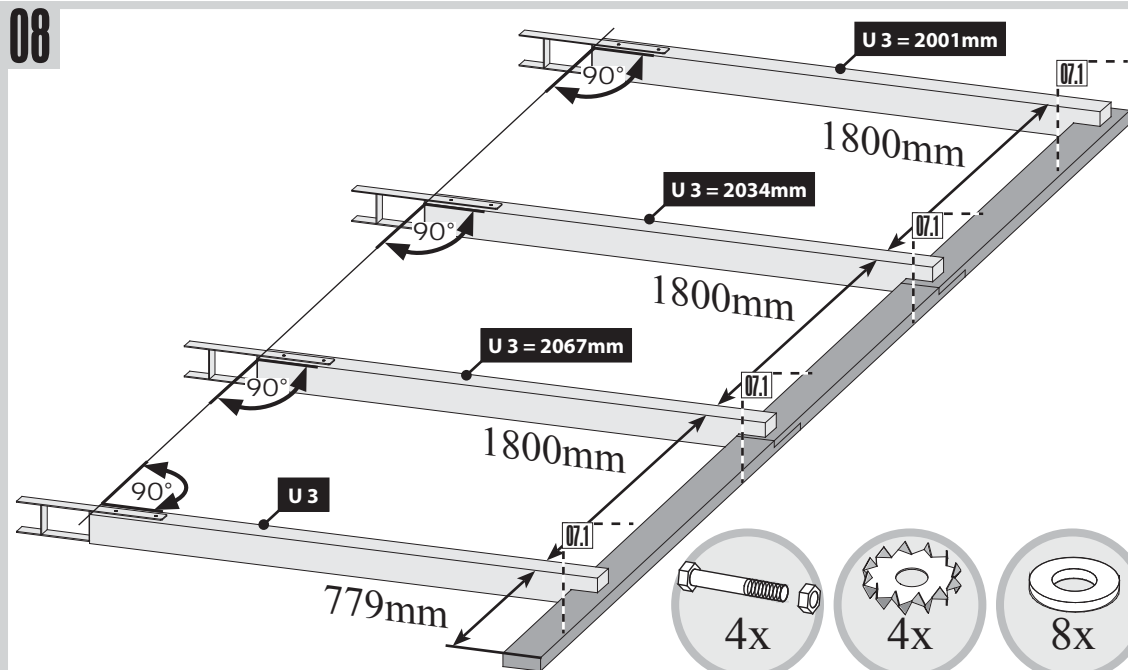

07.1

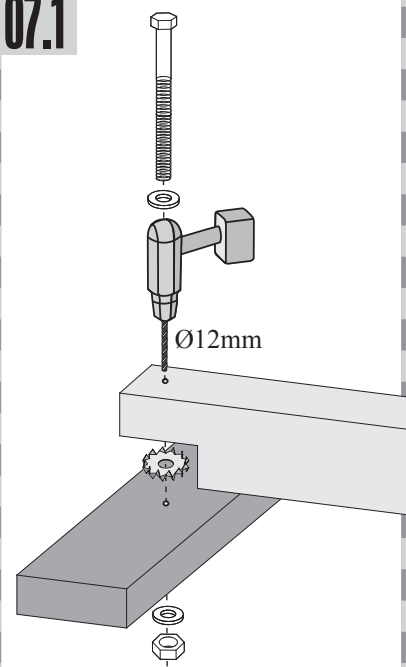

09

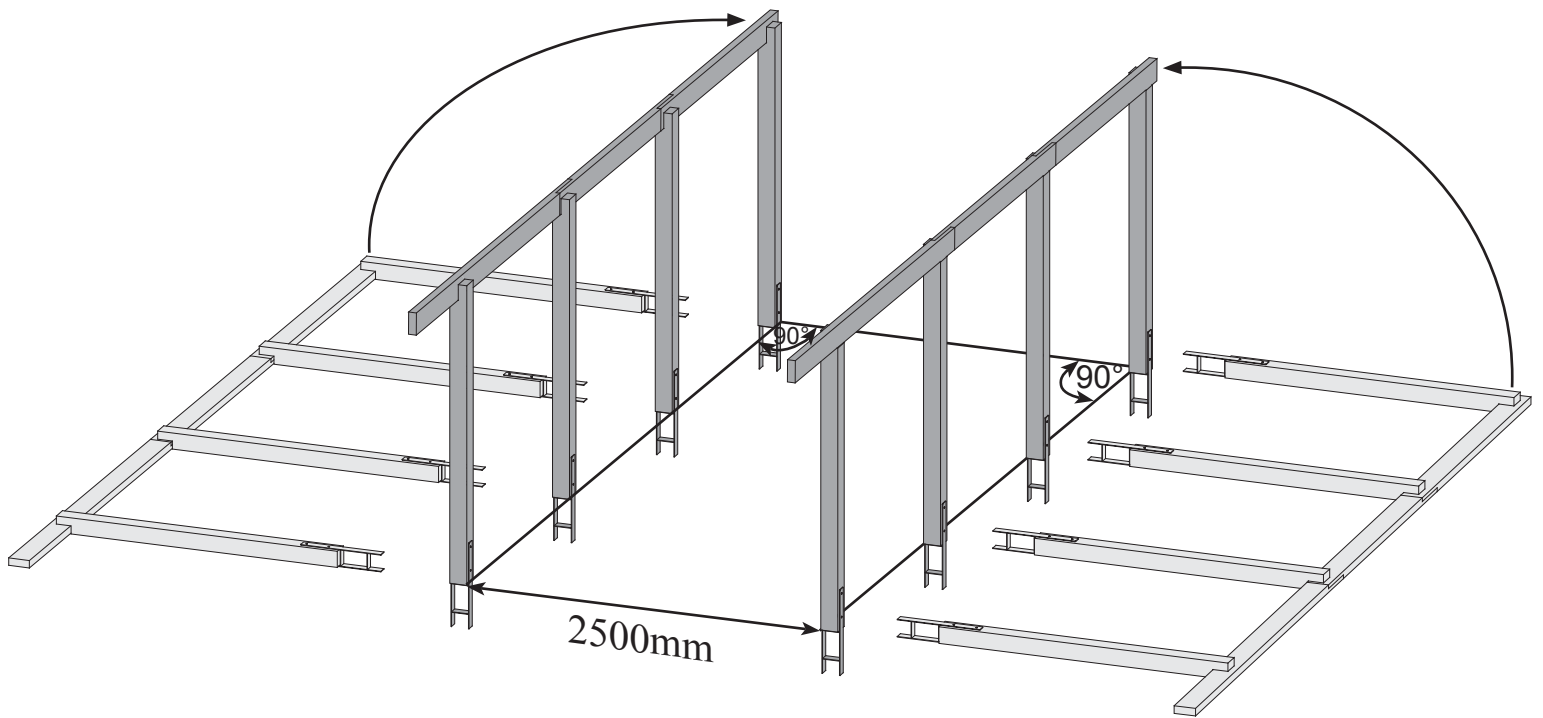
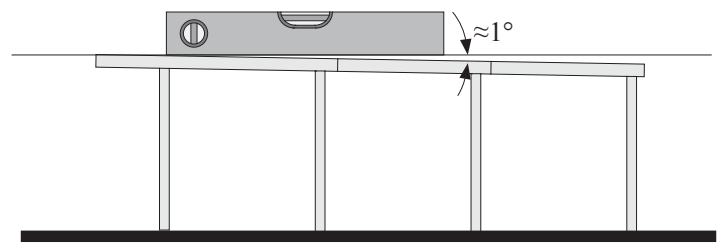

10

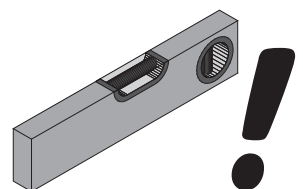
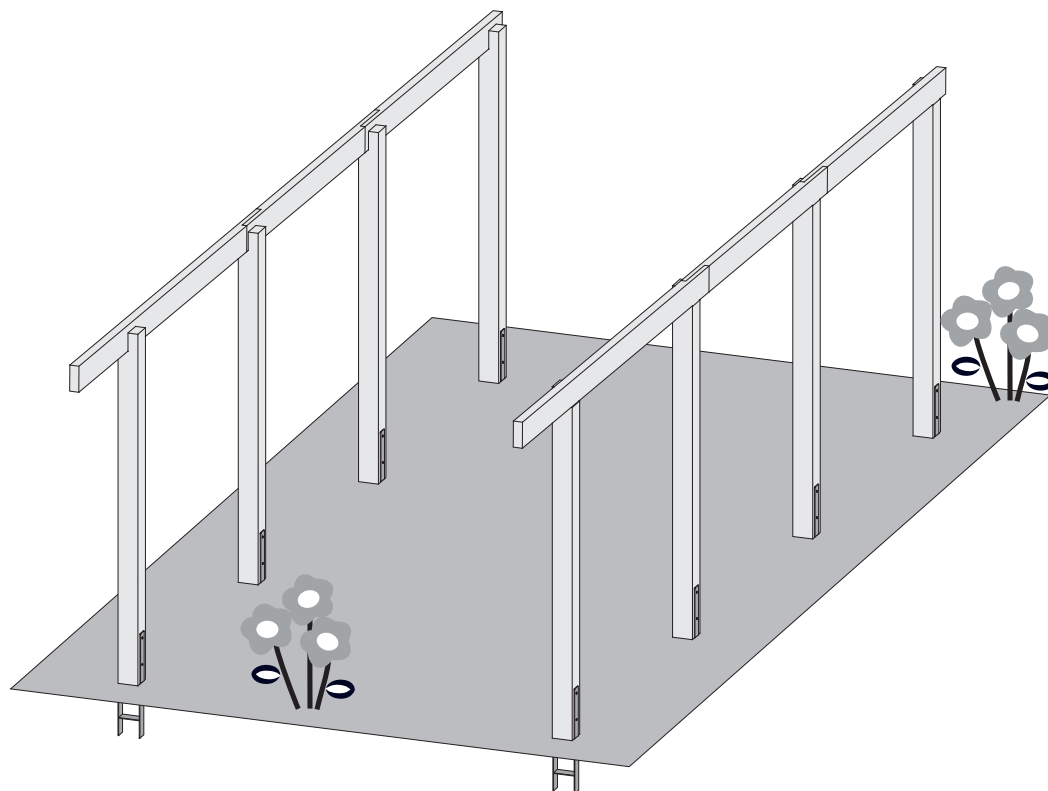

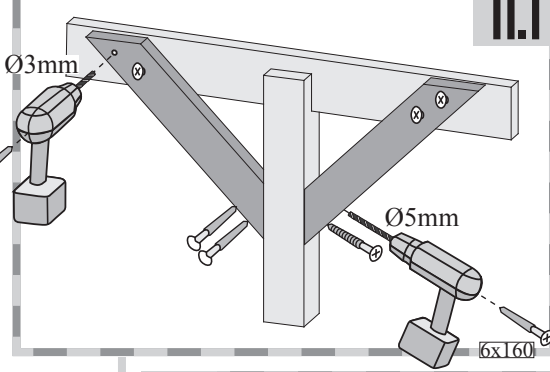
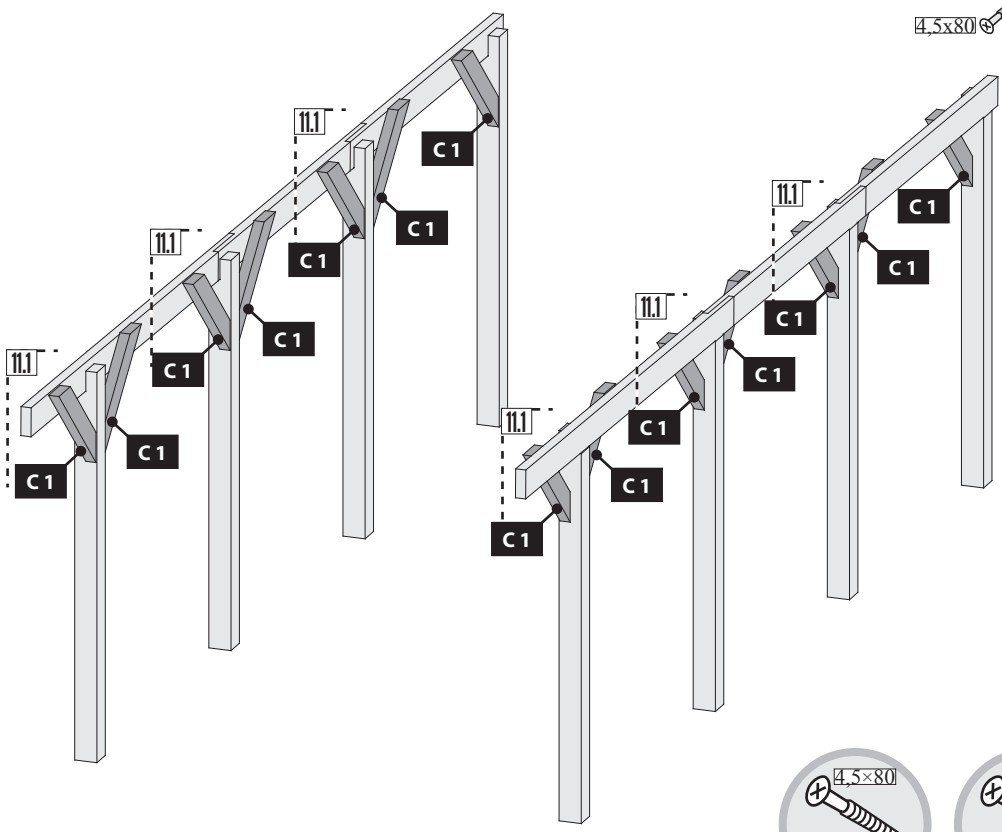

12.1

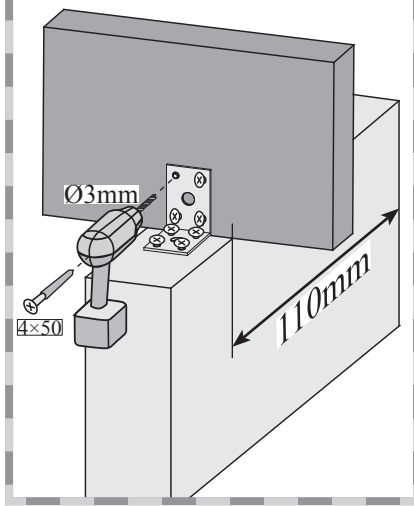

12.2

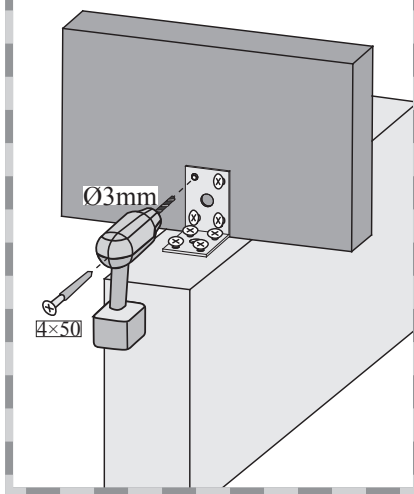

12.3

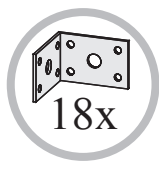
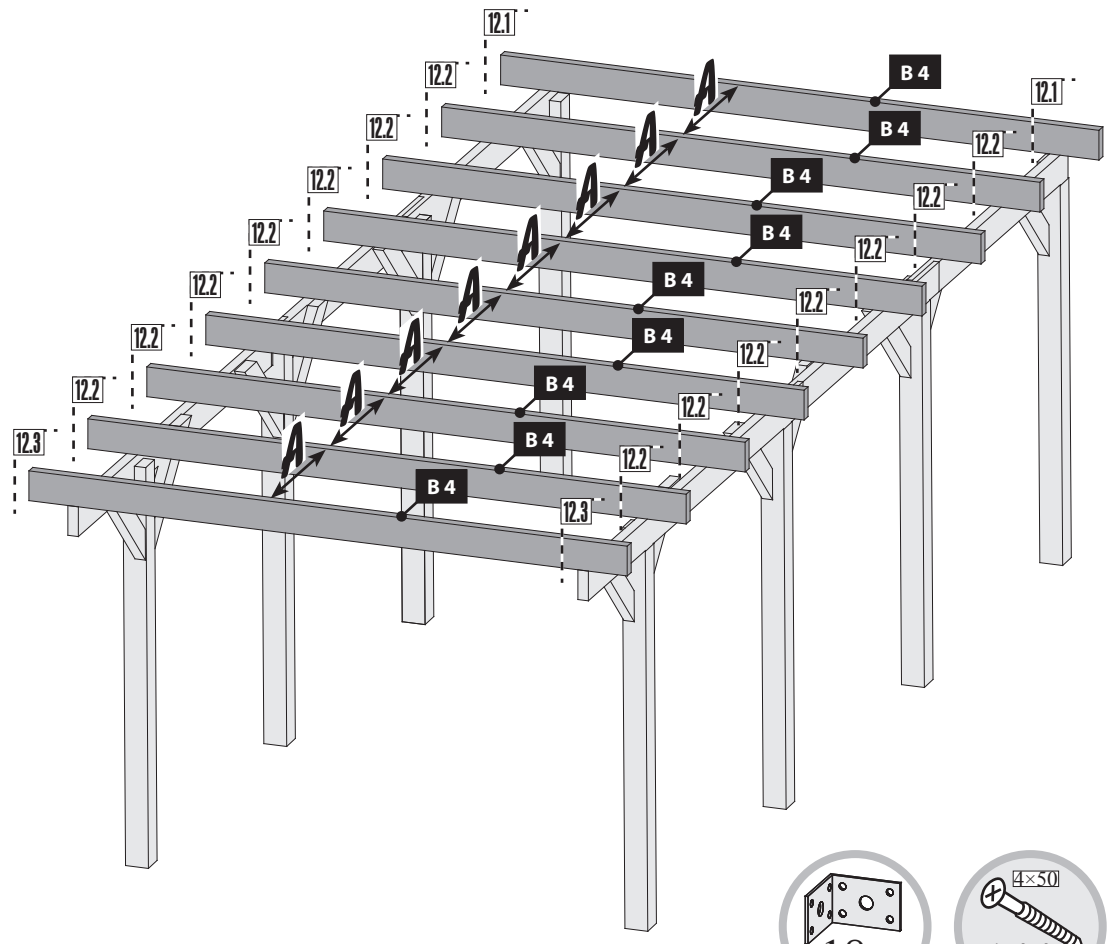
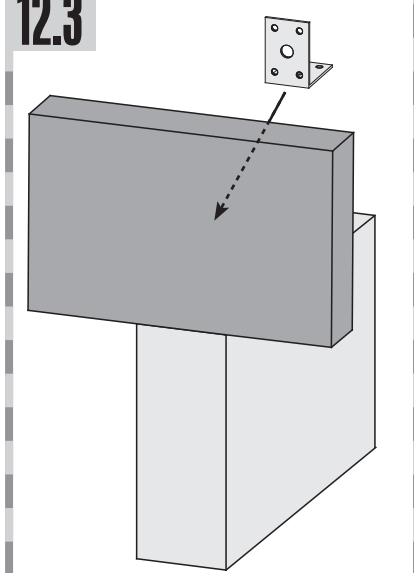

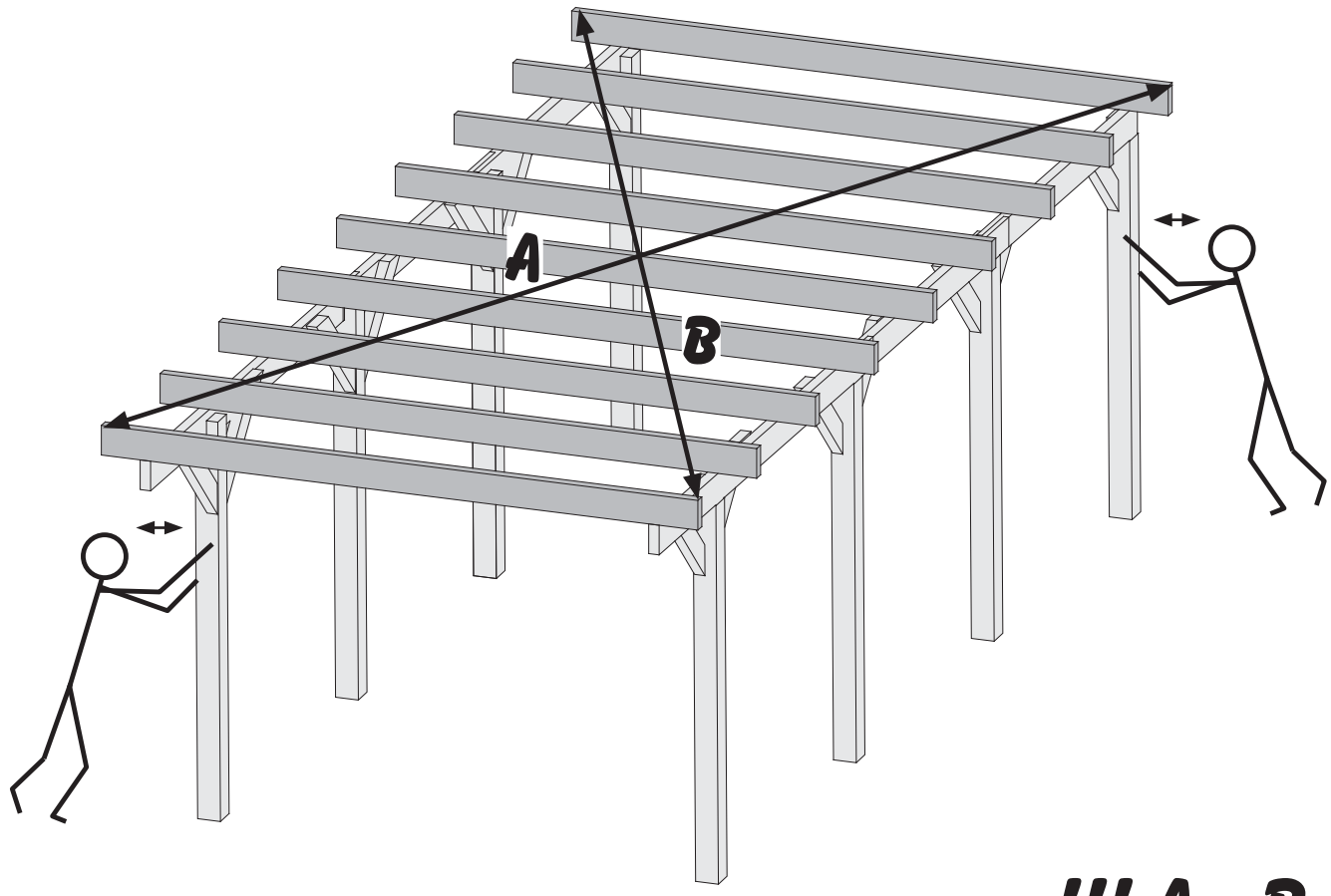

!!! A=B !!!

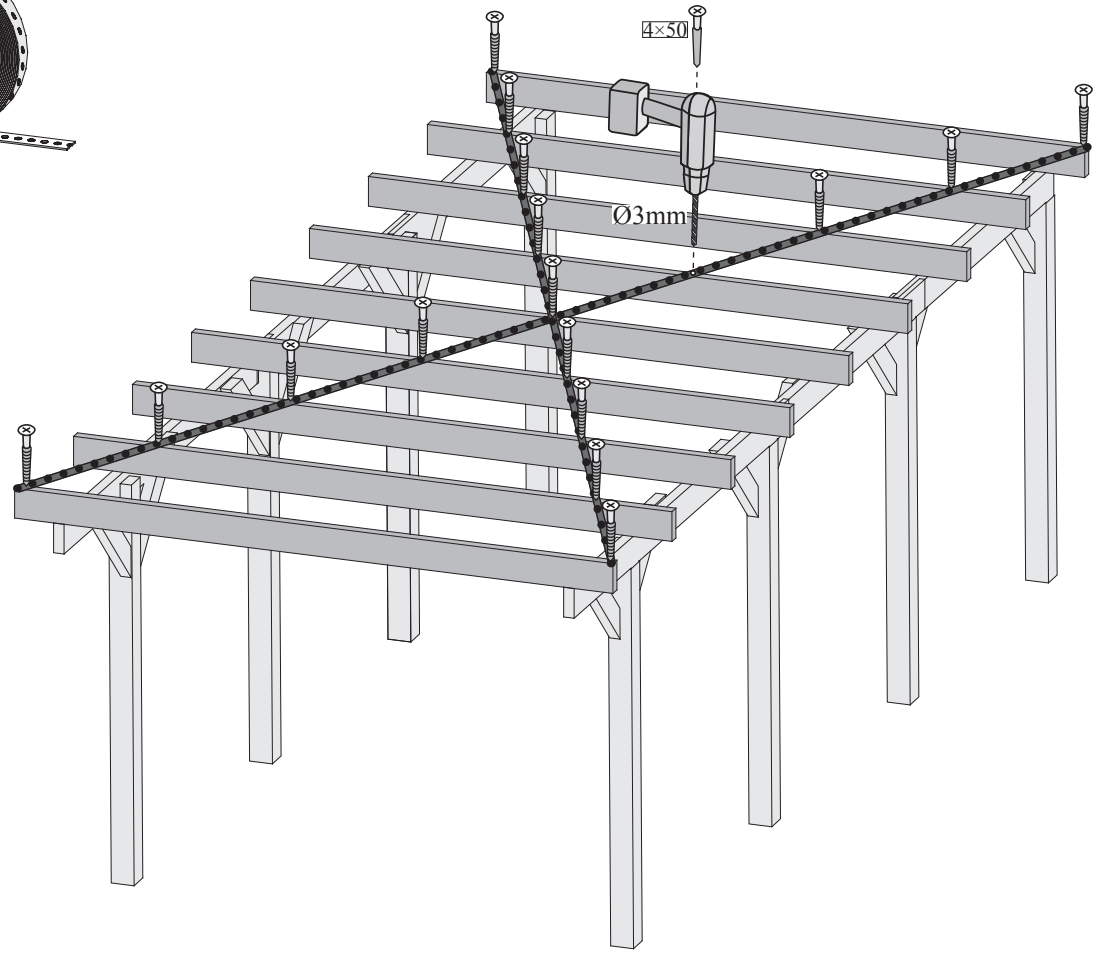
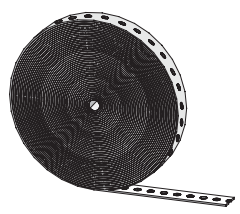

15 2x

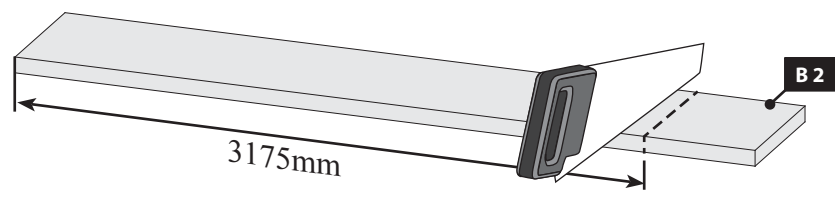

16 2x

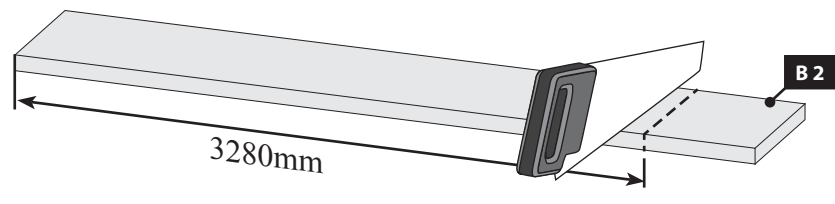

17 2x

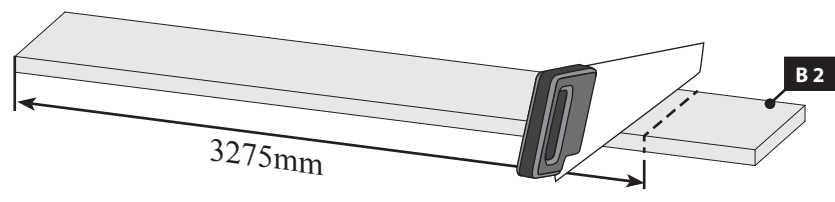

18

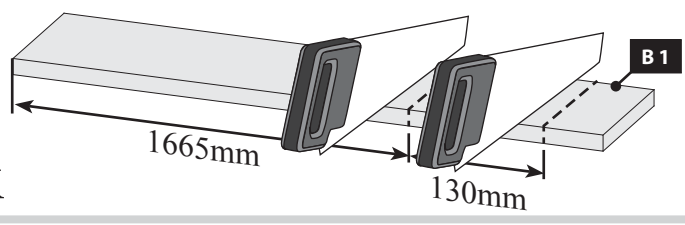

2x

19

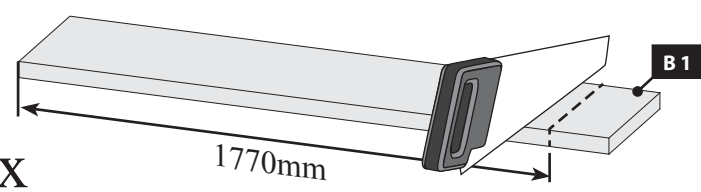

2x

20

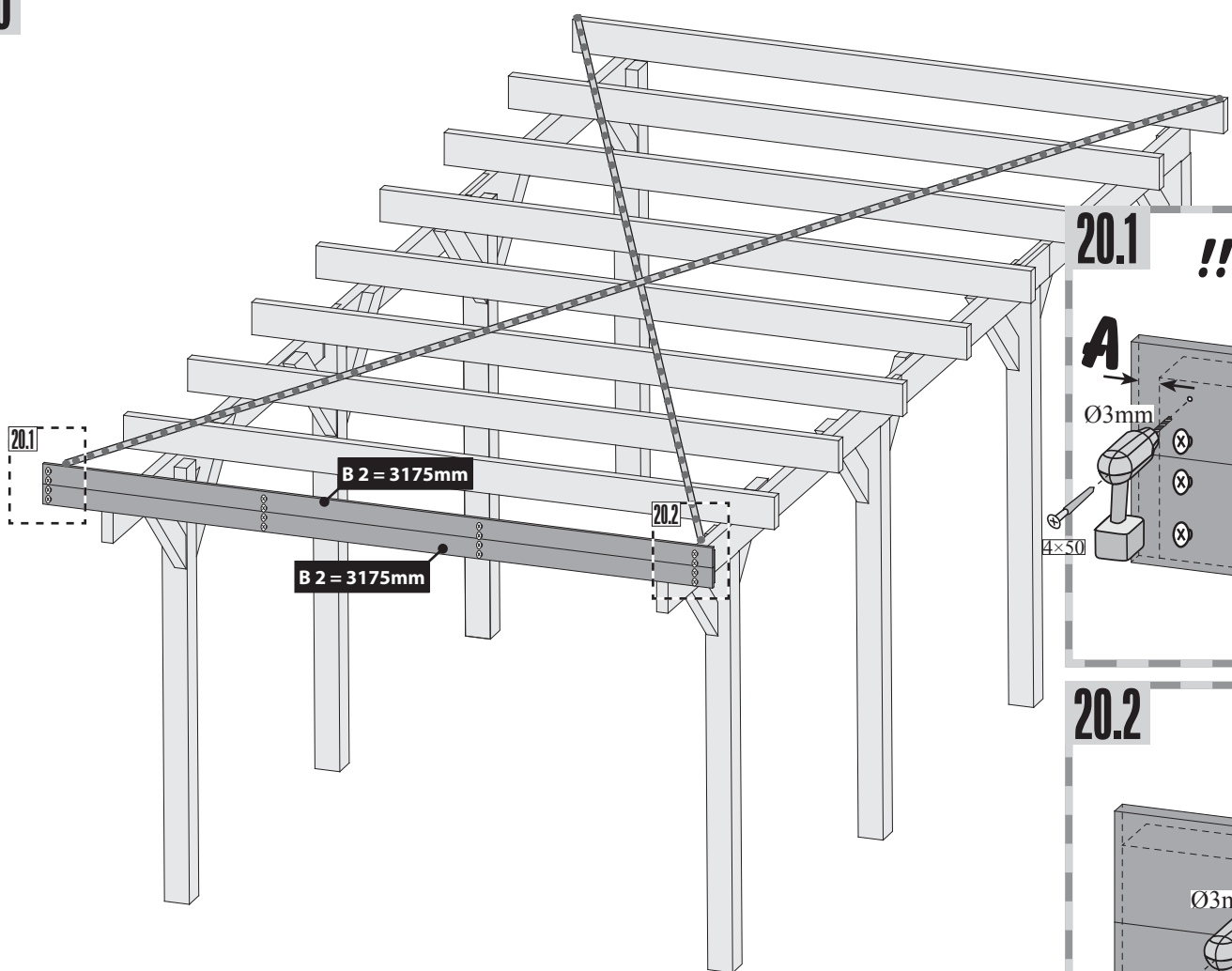

20.1 !!! A=B !!!

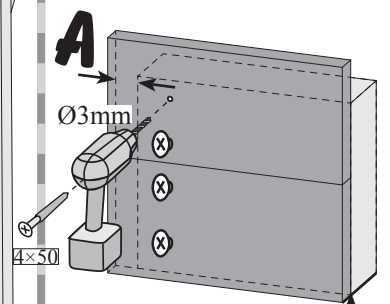

Bündig!
Affleurement!
Gelijk!
Aras!
Flush!
Combacia!
Stejný!

20.2

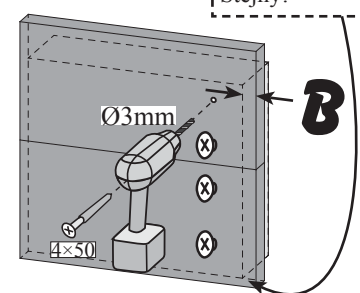

!!! A=B !!!



21

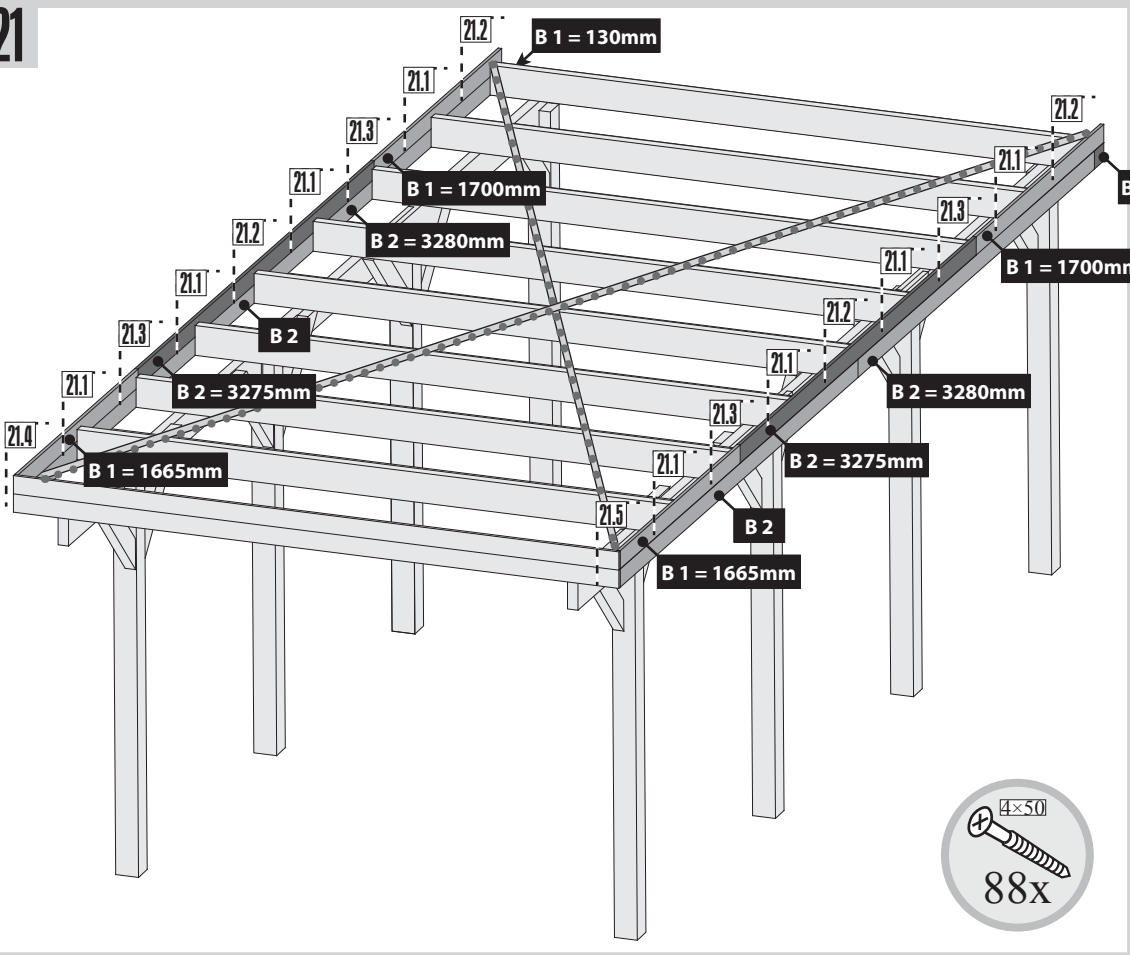

21.1

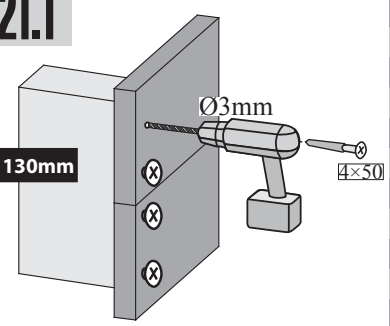

21.2

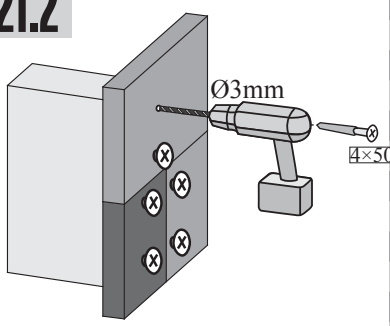

21.3

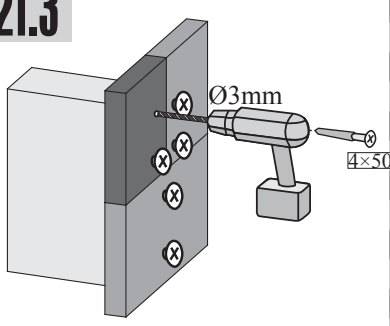

21.4

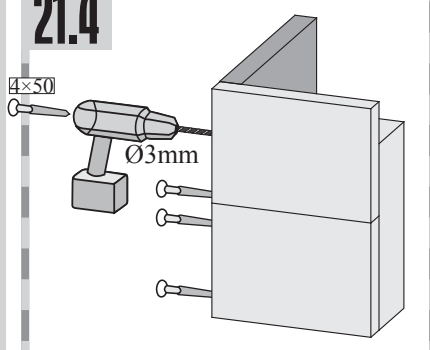

21.5

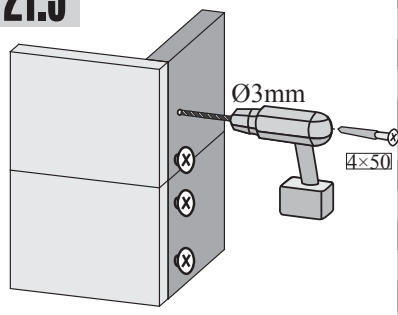

22

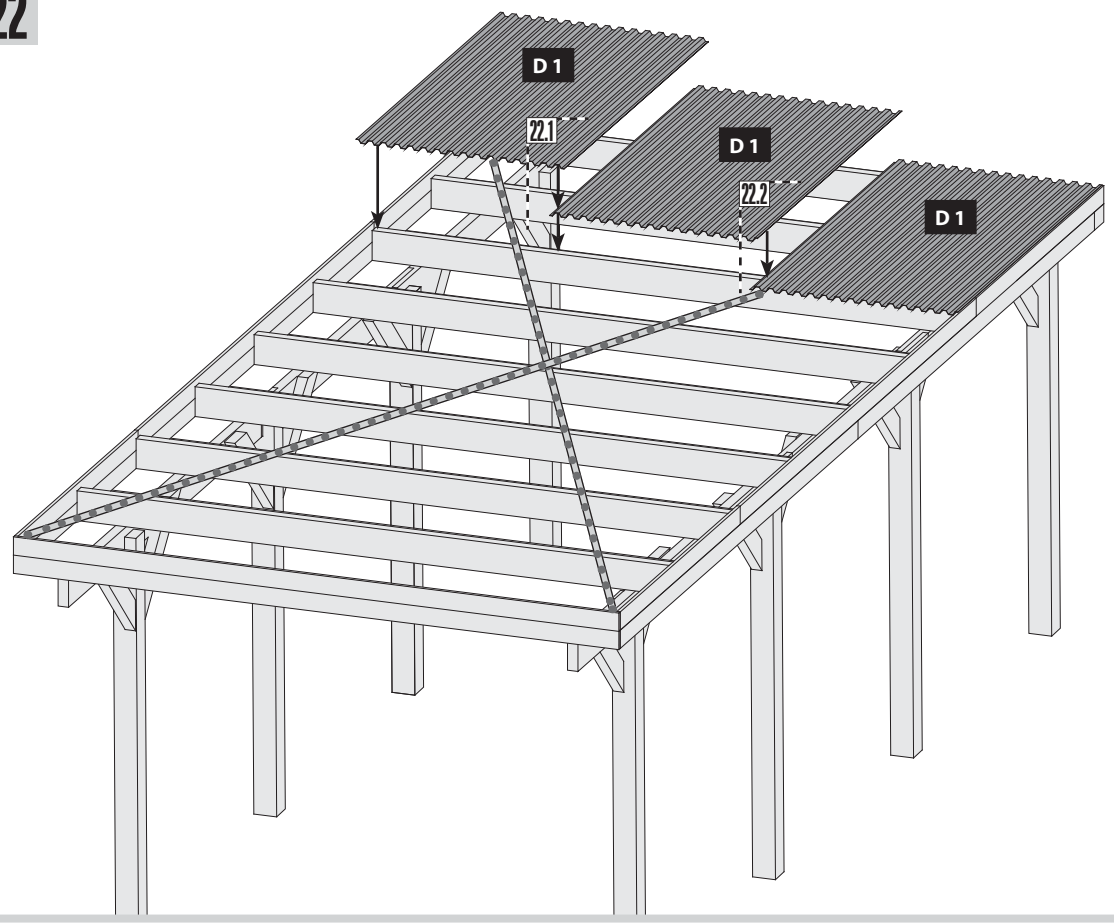

22.1

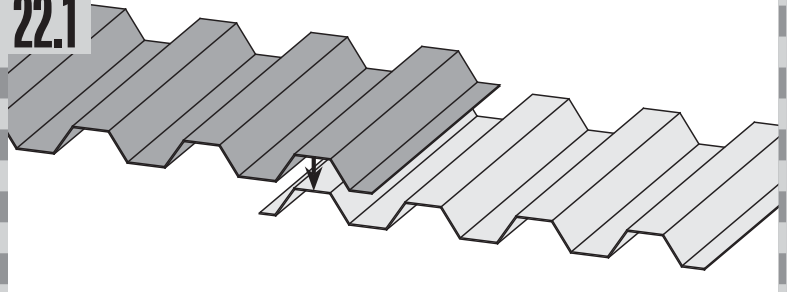

22.2

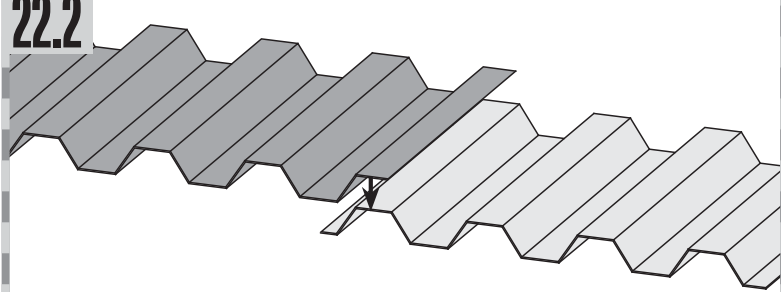

23

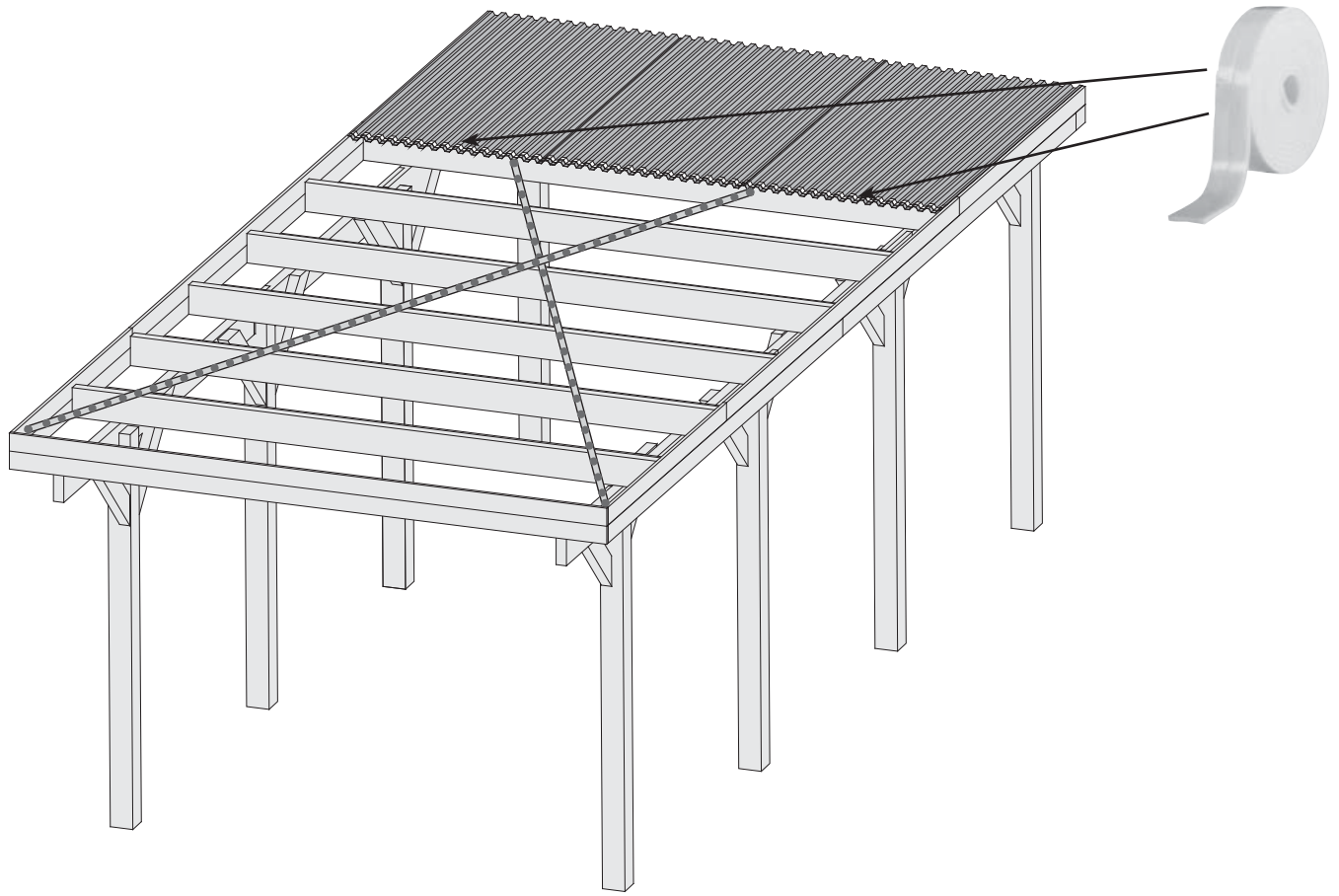

24

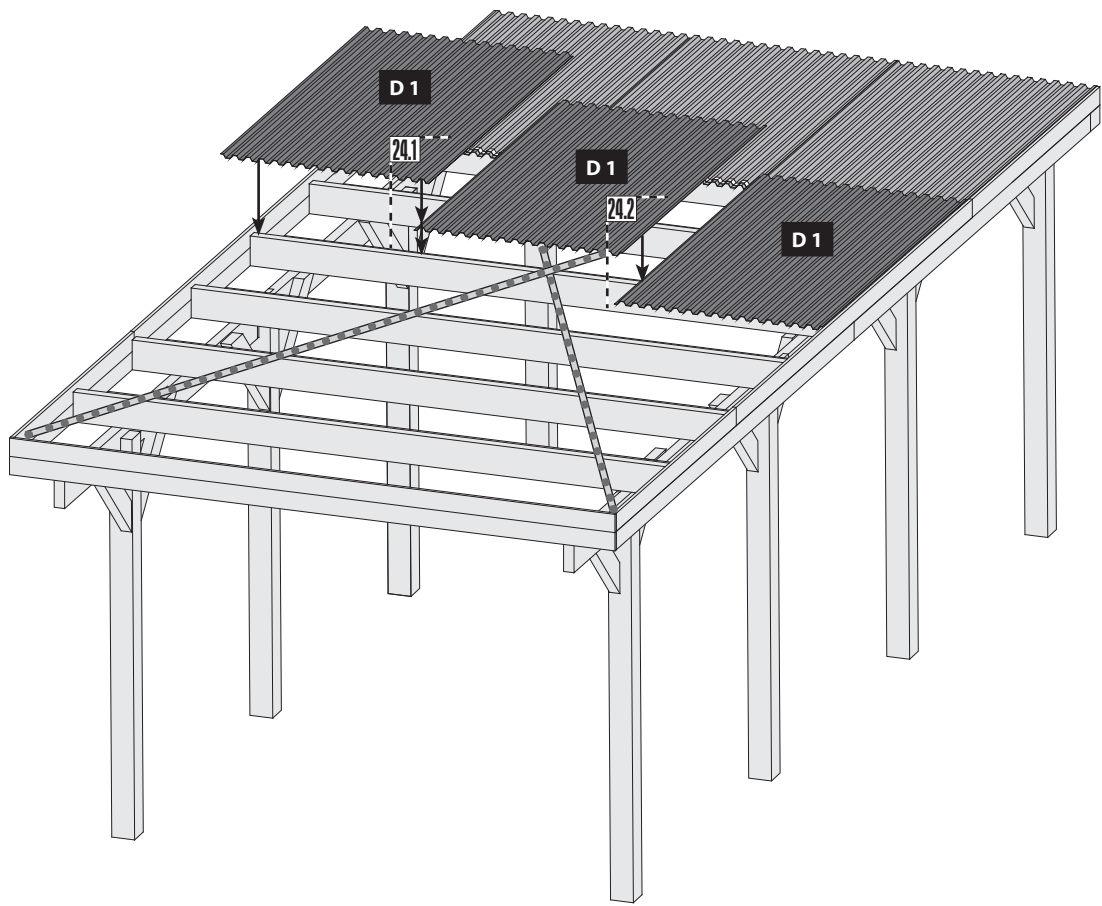

24.1

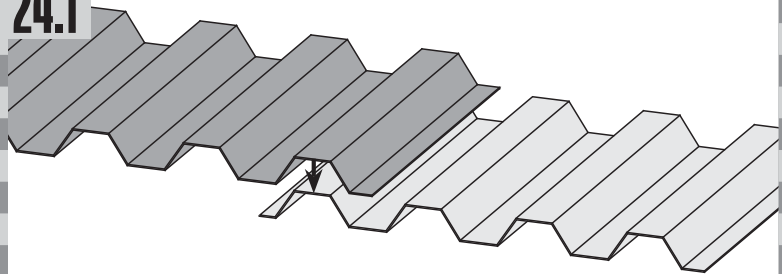

24.2

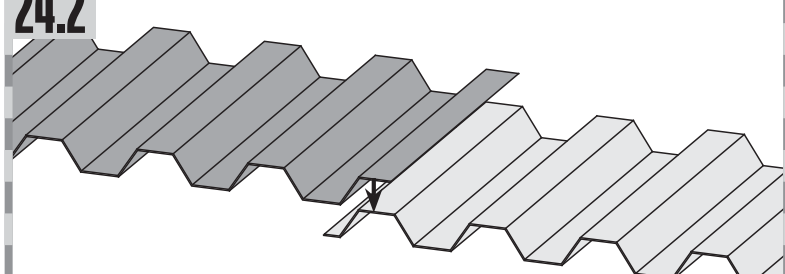

25

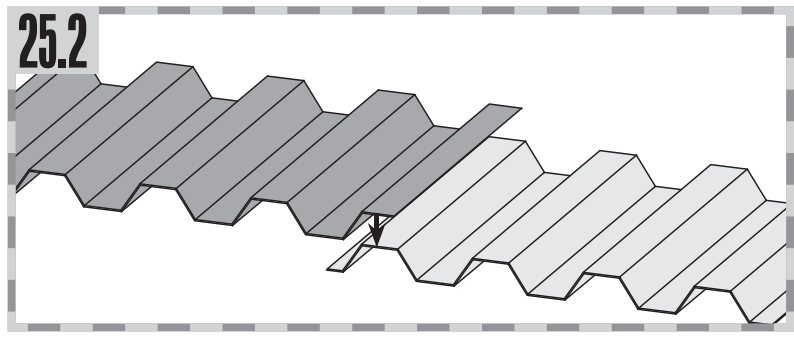
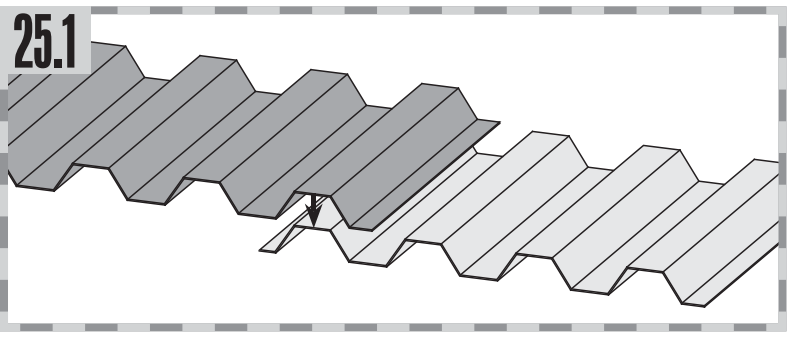
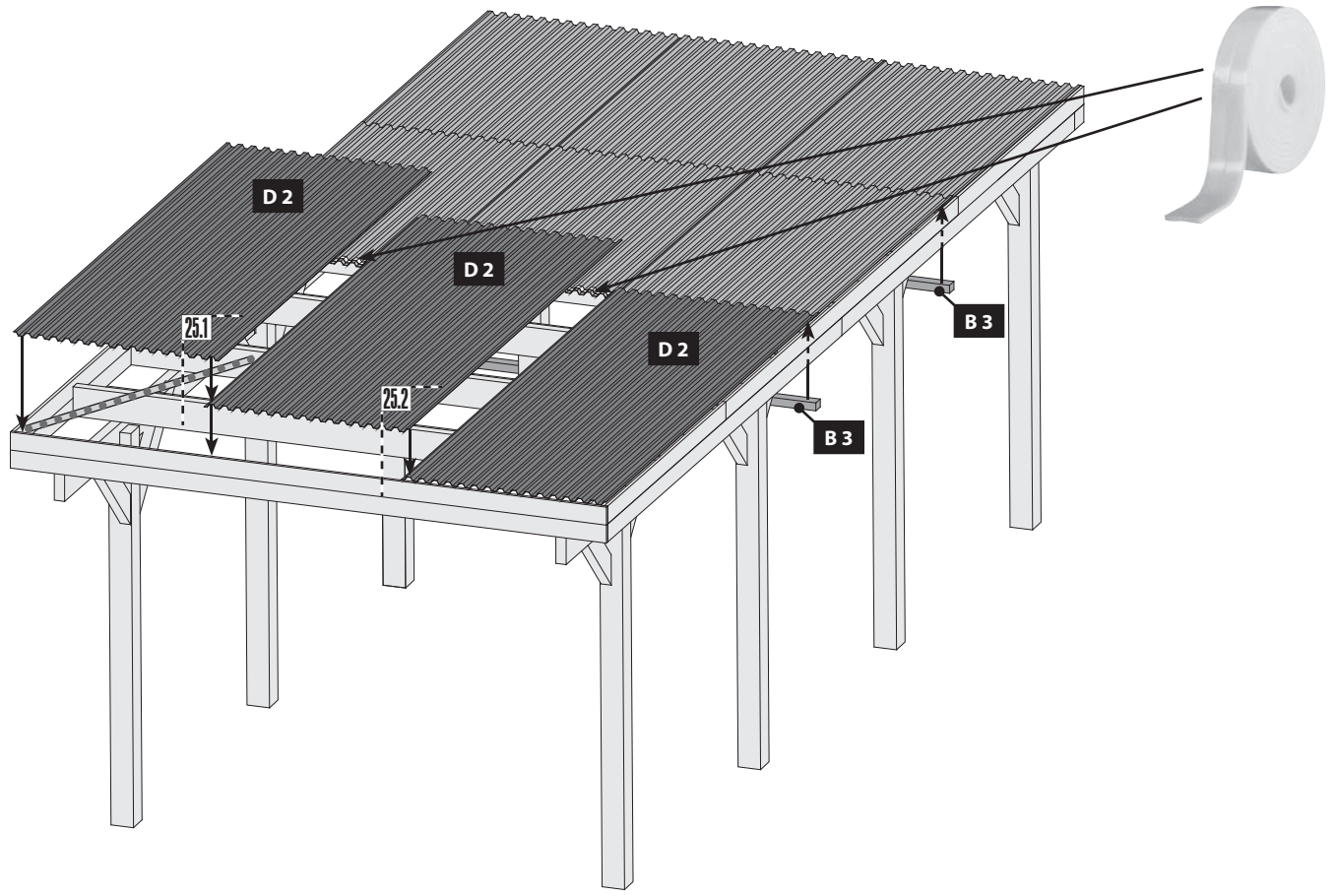

26

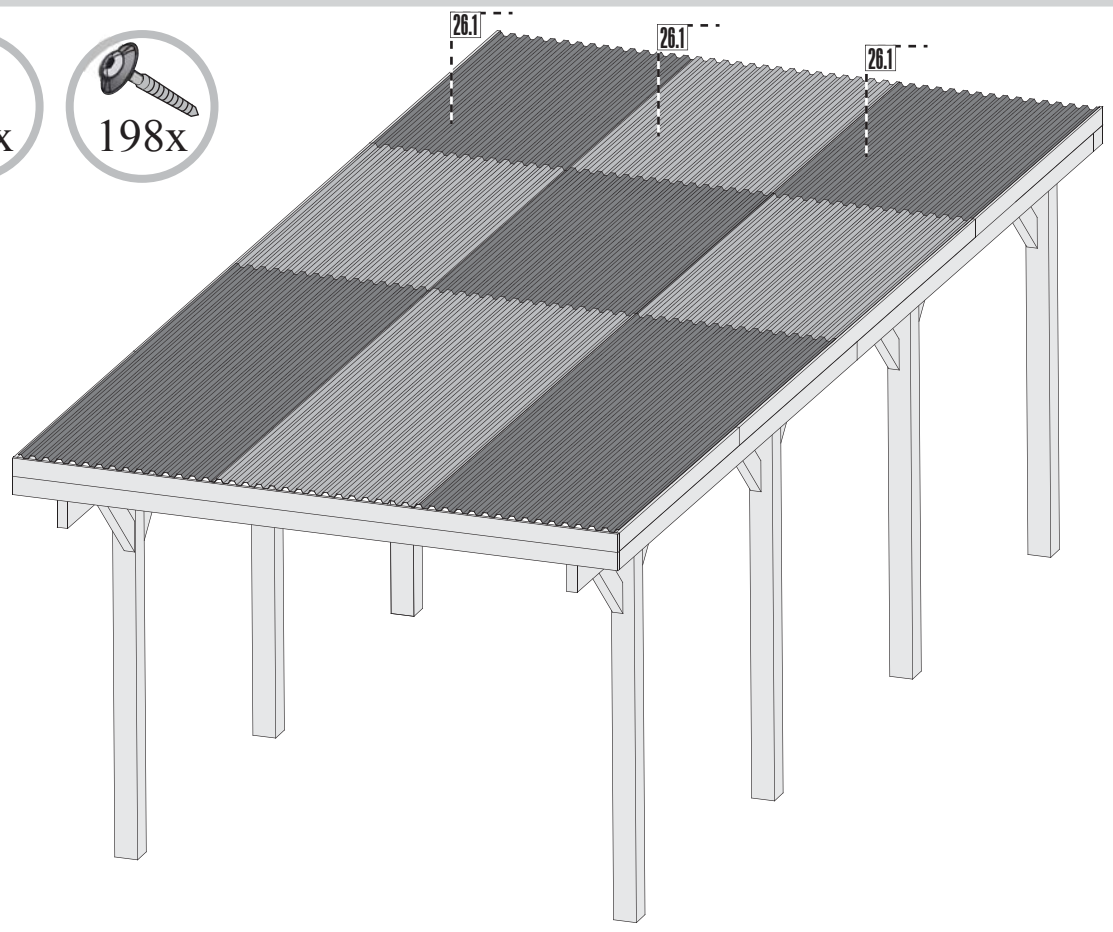

26.1

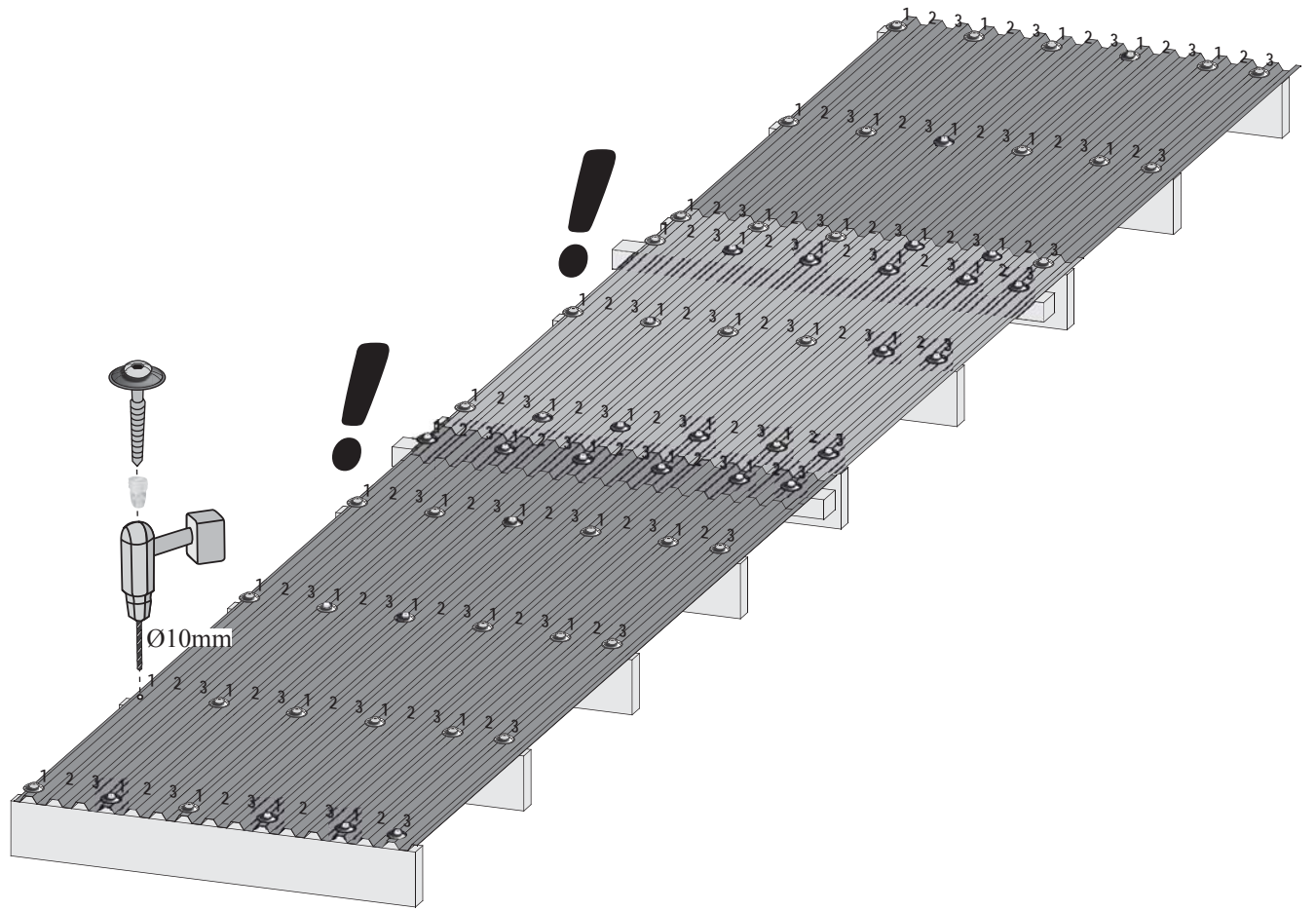



26.1-2

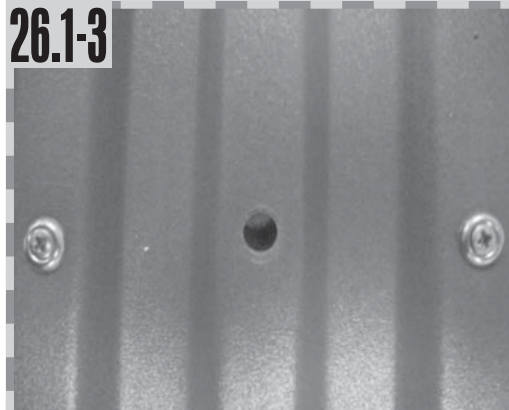

 Abstandshalter und Schrauben auf der Bedachungsplatte ablegen

26.1-3



 10mm Bohrloch mit Metall- oder Holzbohrer in die Bedachungsplatte vorbohren

26.1-4

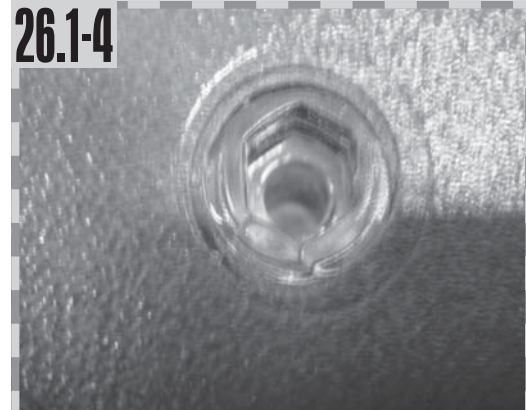

 Abstandshalter zB mit einem Torx 20-Bit unter die Bedachungsplatte drehen

26.1-5

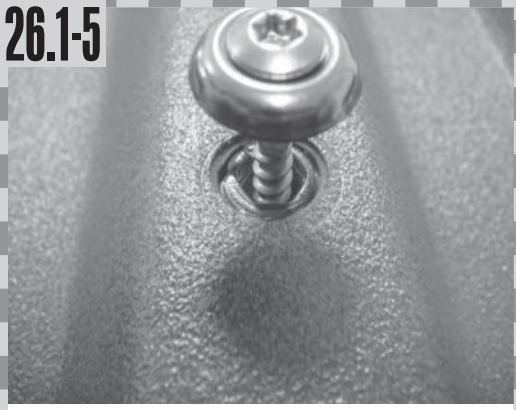

 Spenglerschraube setzen...

26.1-6

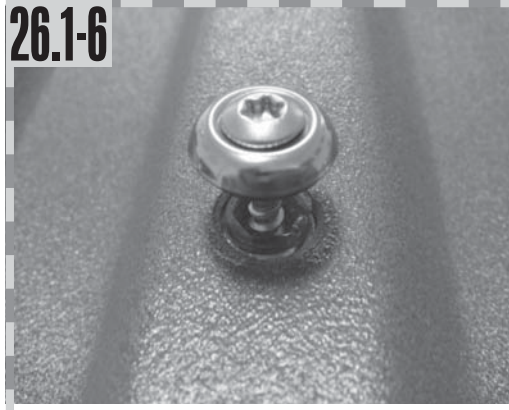

 ... und mit demselben Torx 20-Bit einschrauben...

26.1-7

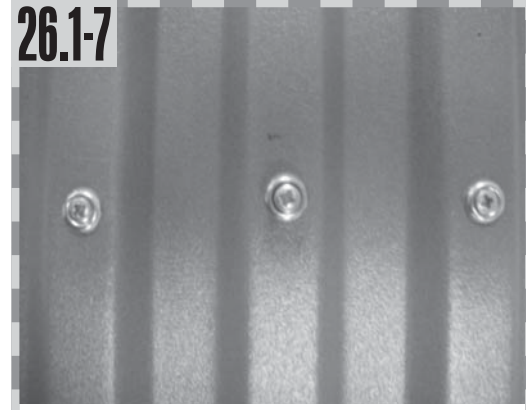

 ... und ohne Zwangung fixieren.
Fertig!

27 2x

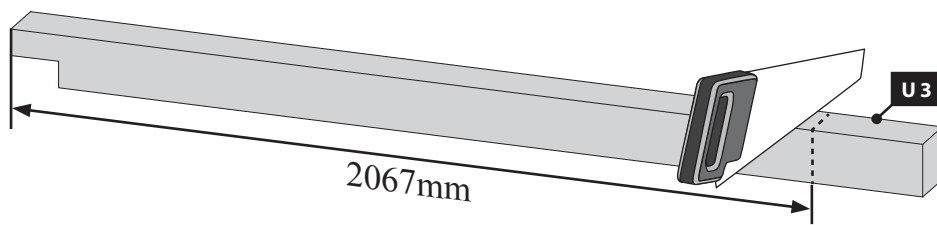

28 2x

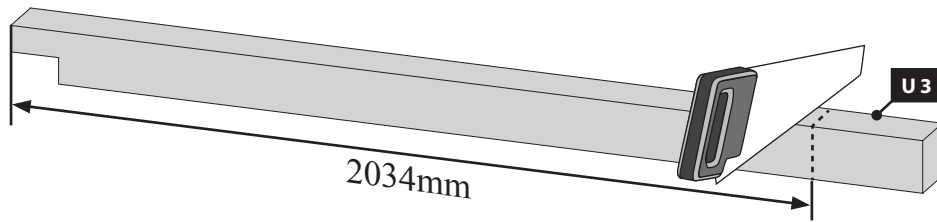

29 2x

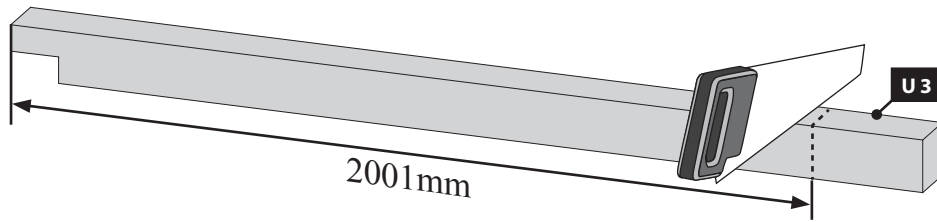



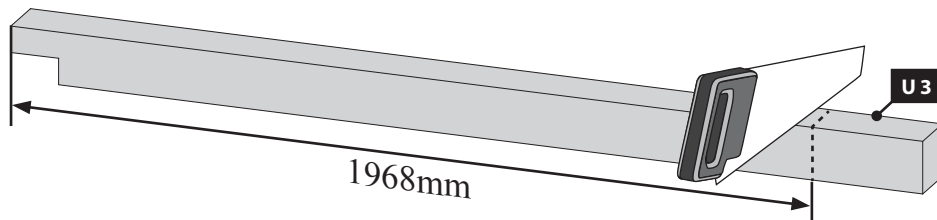

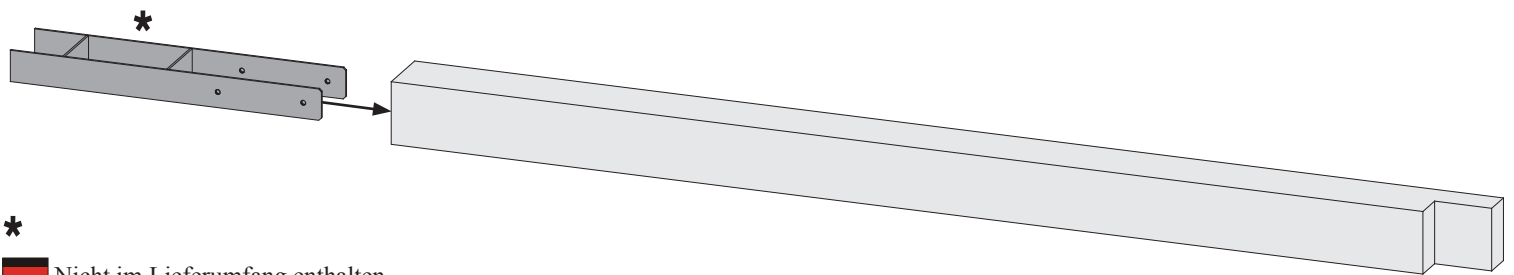

30 2x



31 10x



- ***
-  Nicht im Lieferumfang enthalten
 -  Niet bijgeleverd
 -  Not included
 -  Non comprises dans la livraison
 -  No forman parte del suministro
 -  Non incluso
 -  V ceně není zahrnuto

32 10x

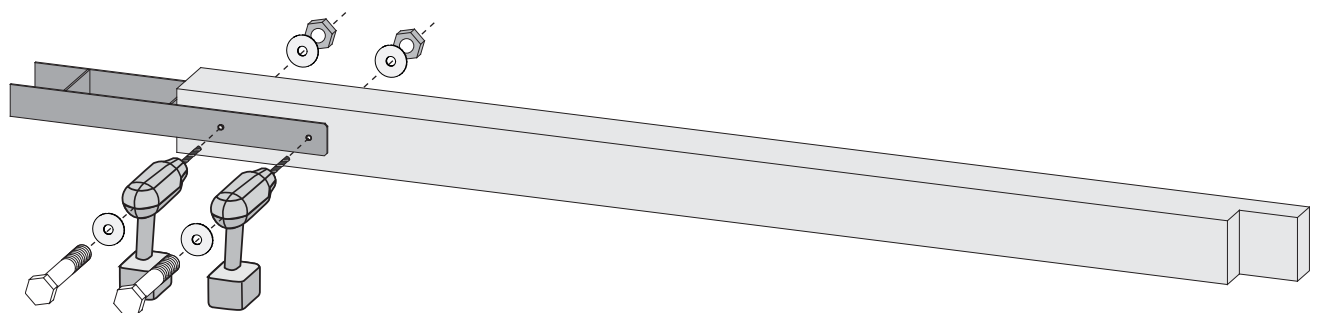

33 2x

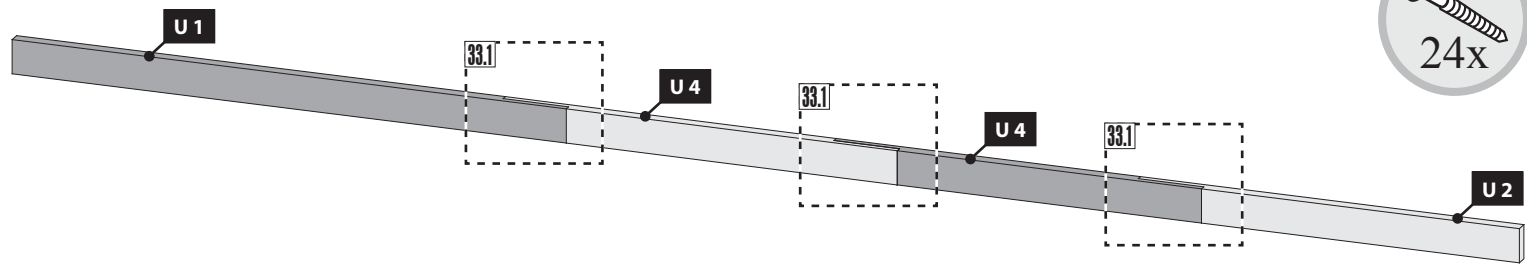

33.1

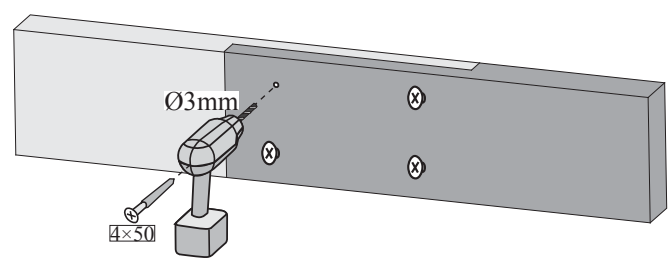

34

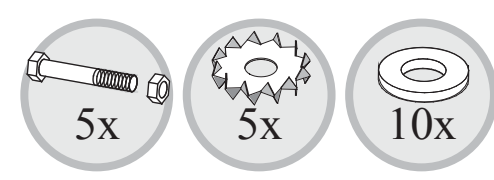
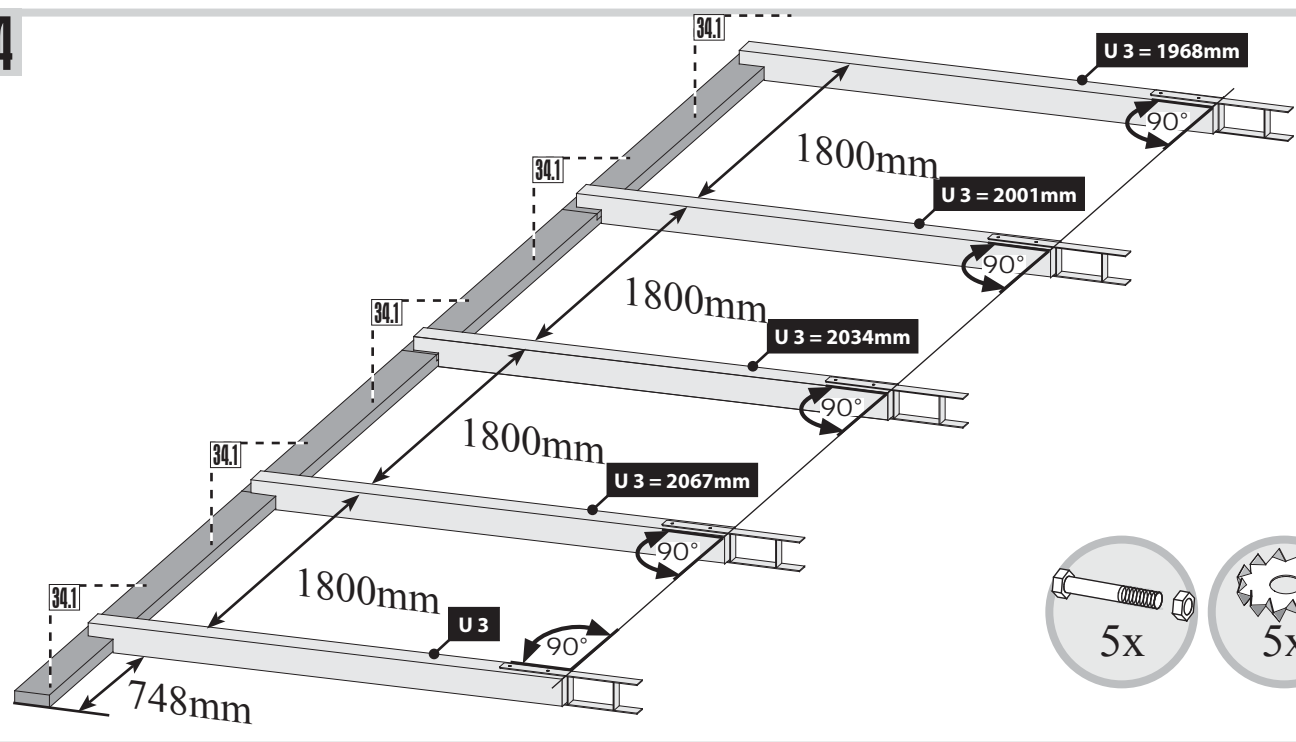

35

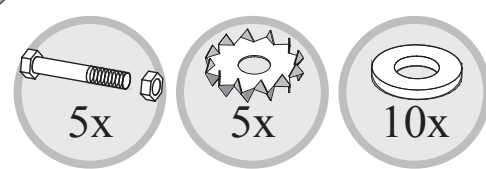
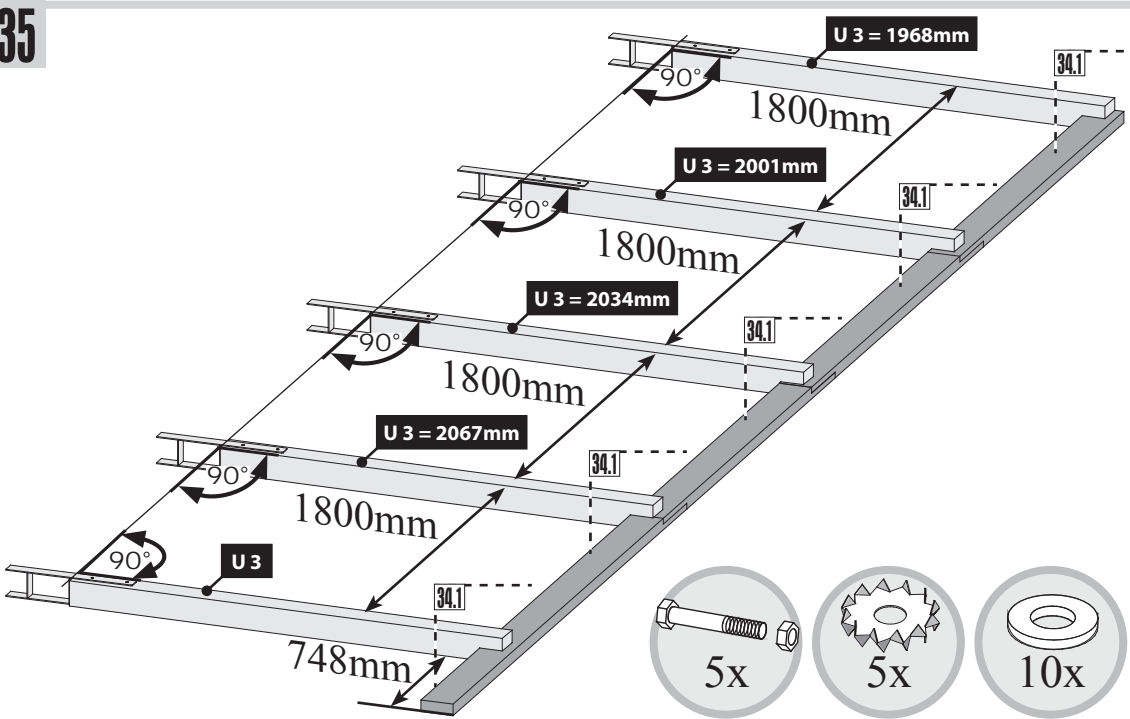

34.1

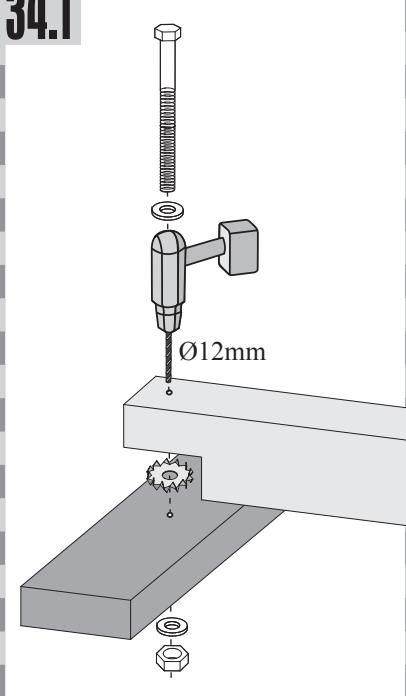

36

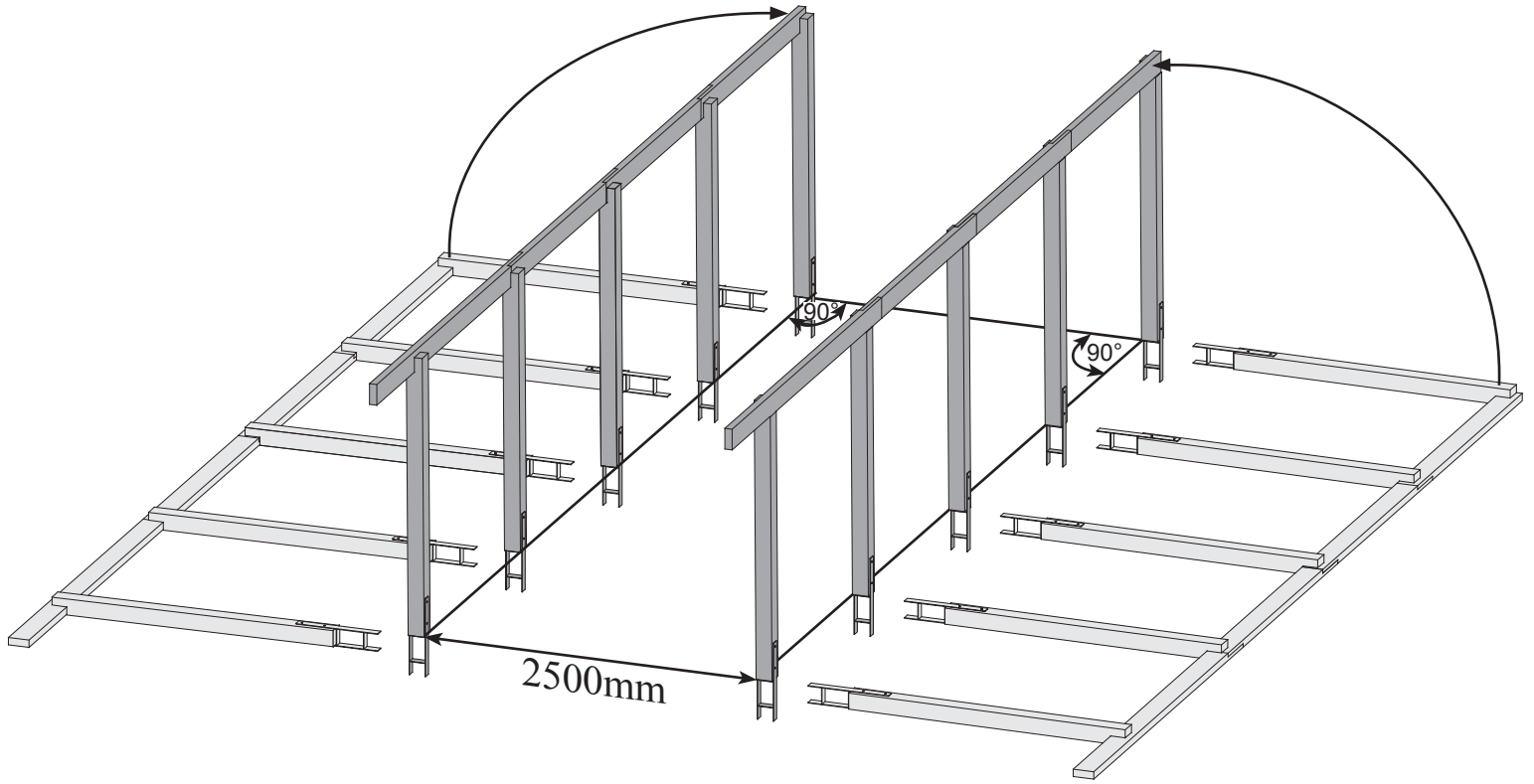
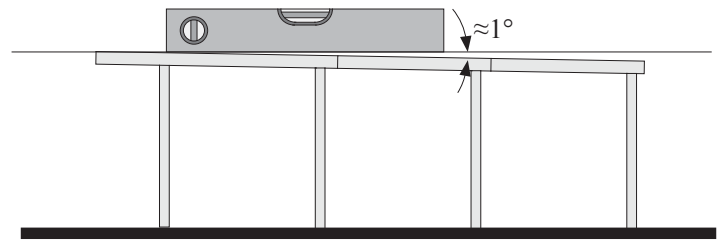

37

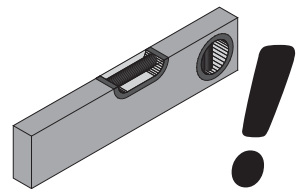
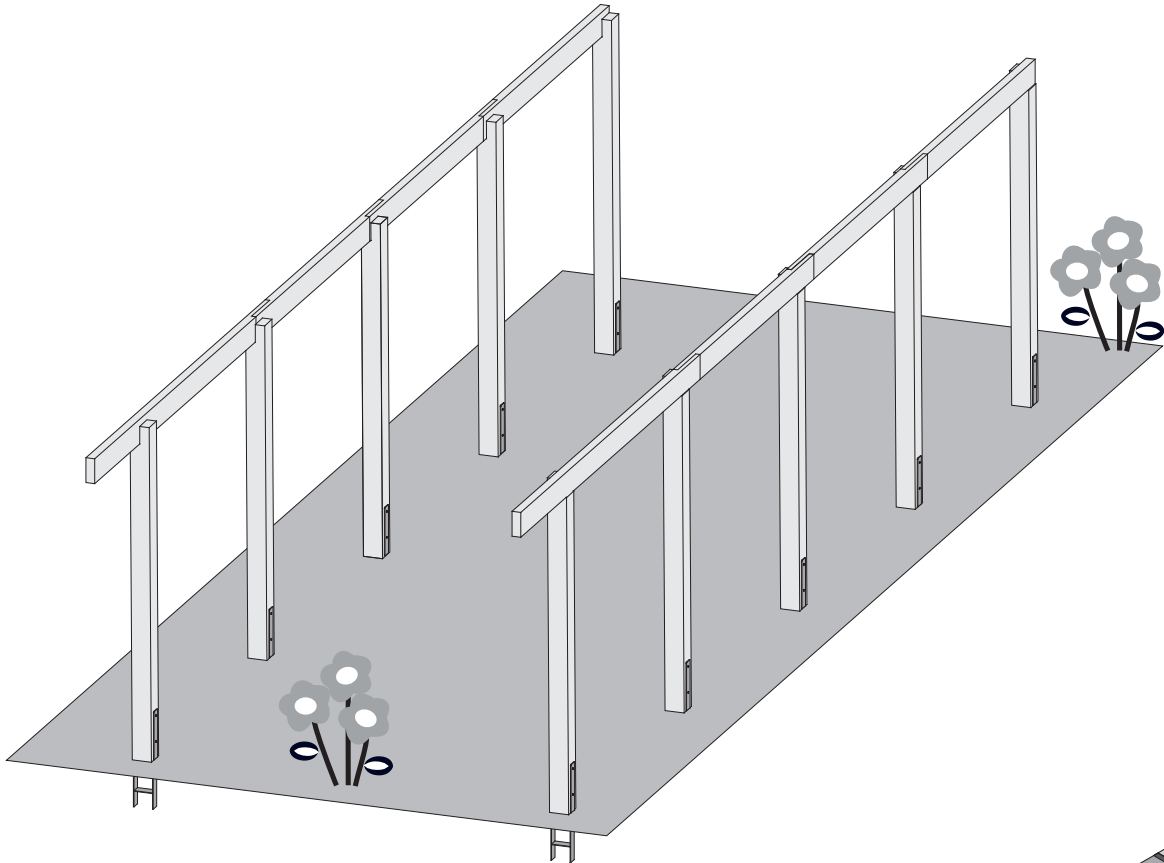

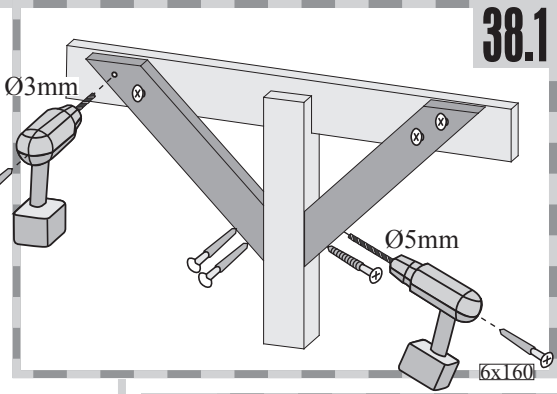
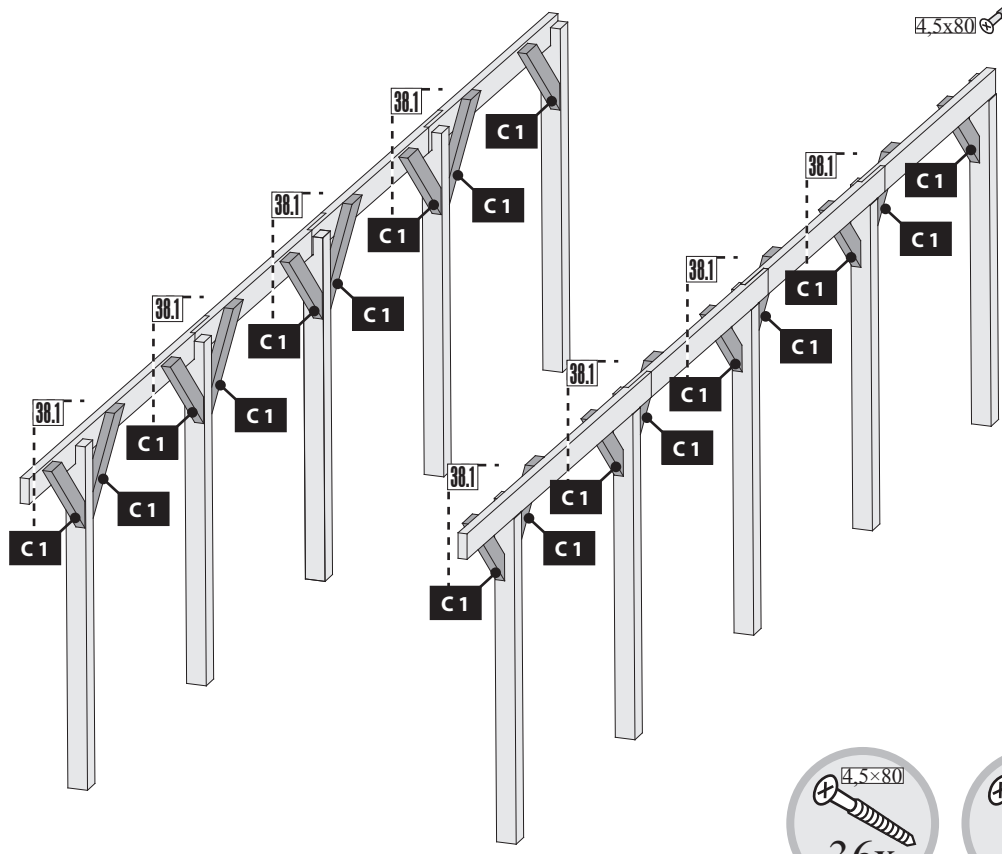

39.1

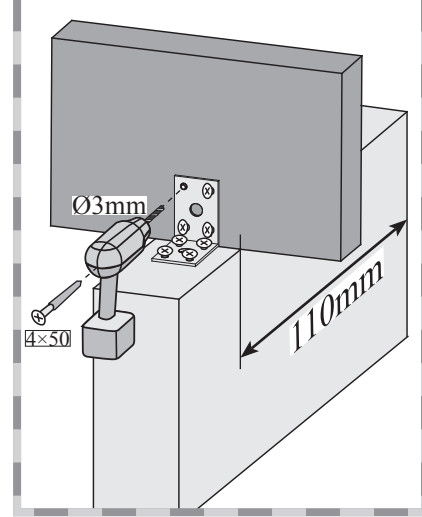

39.2

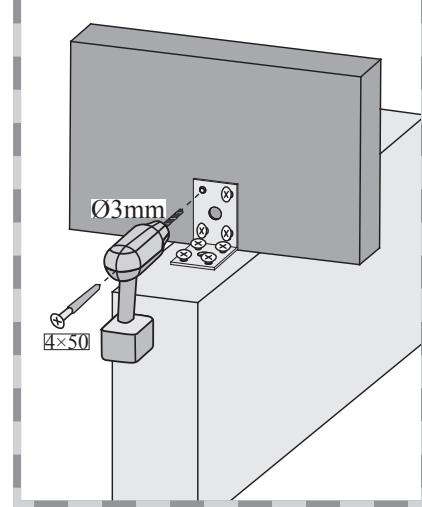

39.3

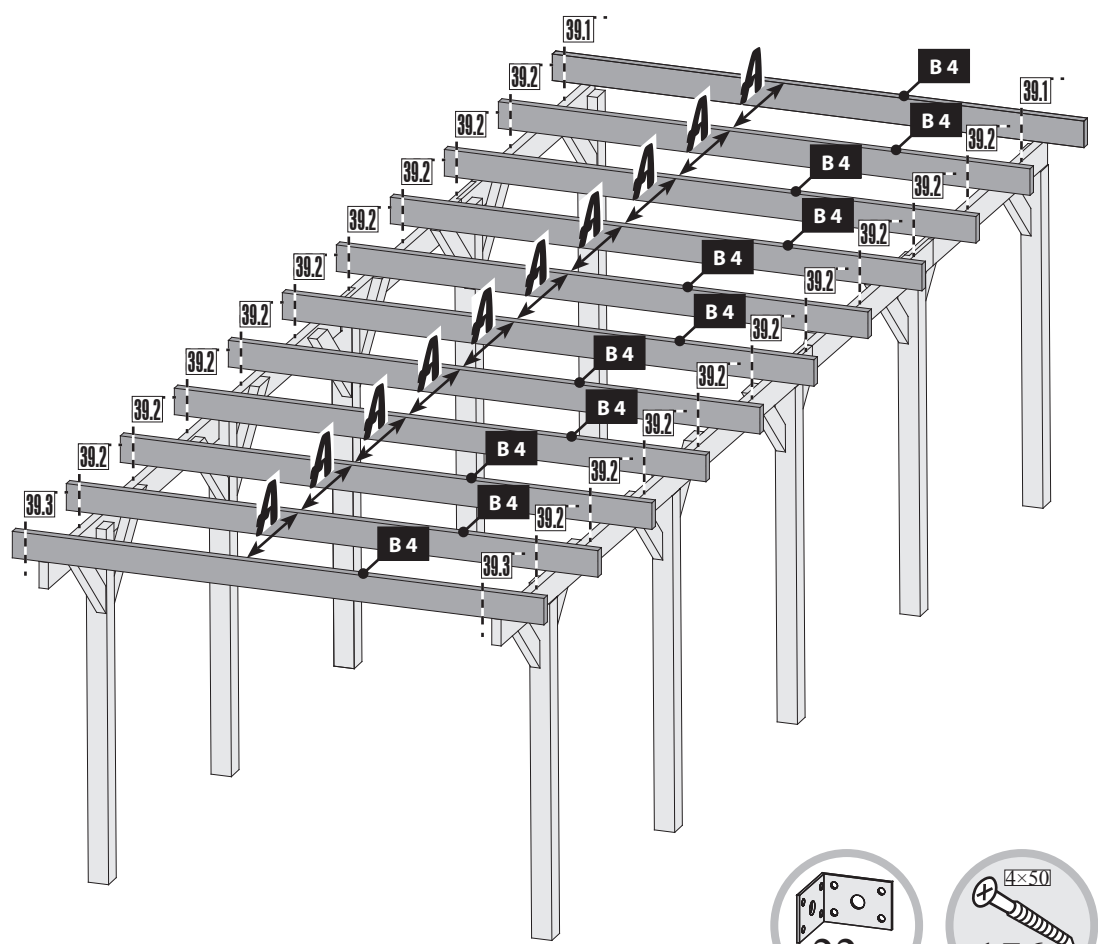
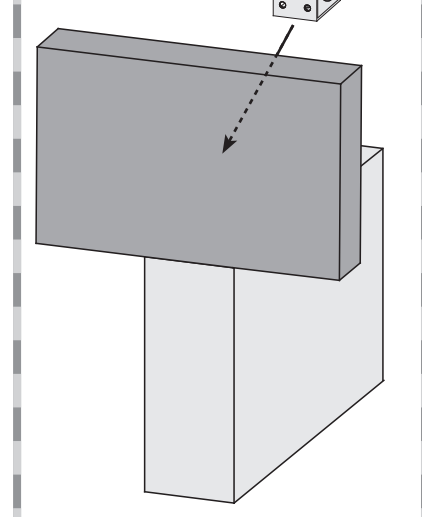

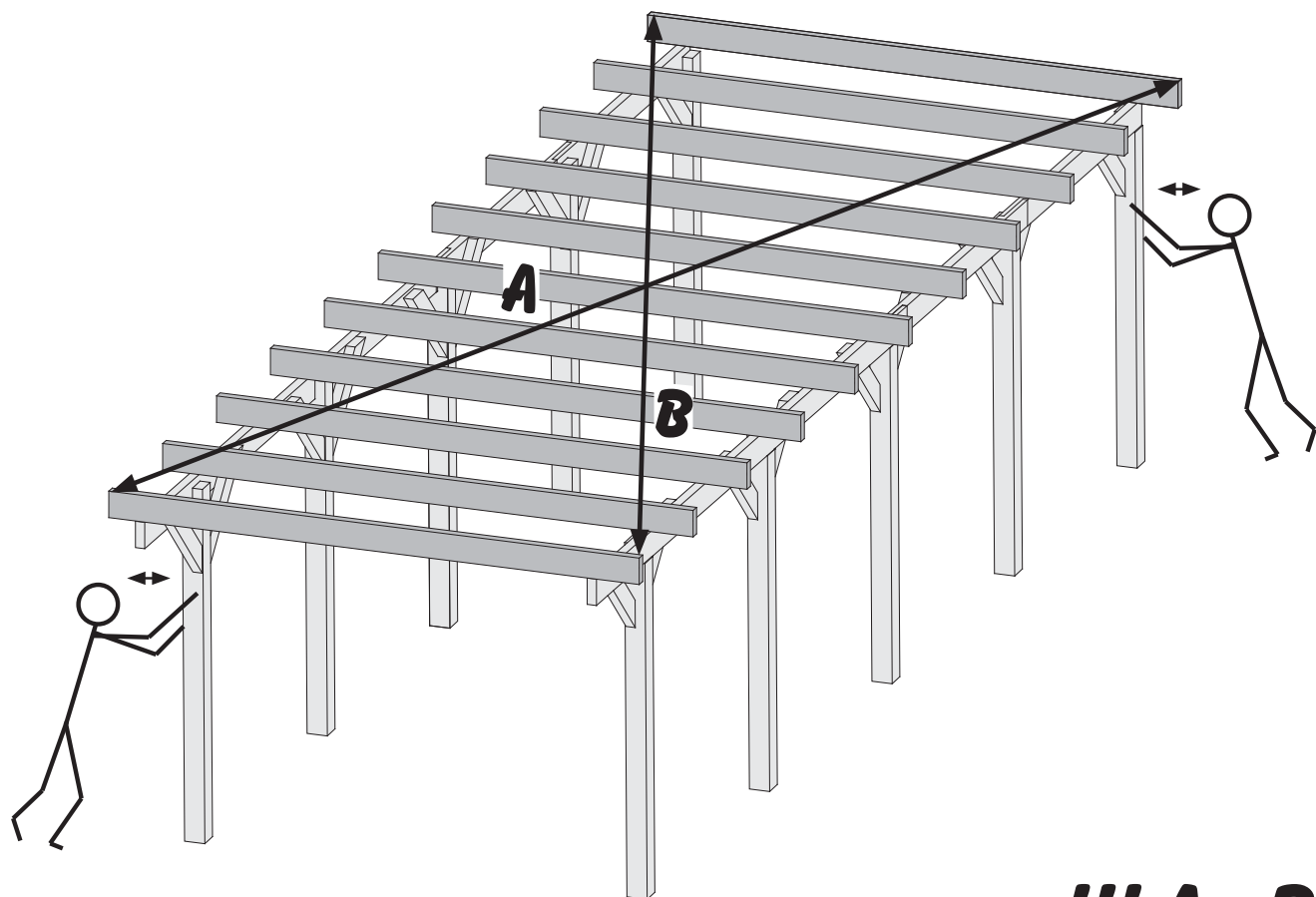

!!! A=B !!!

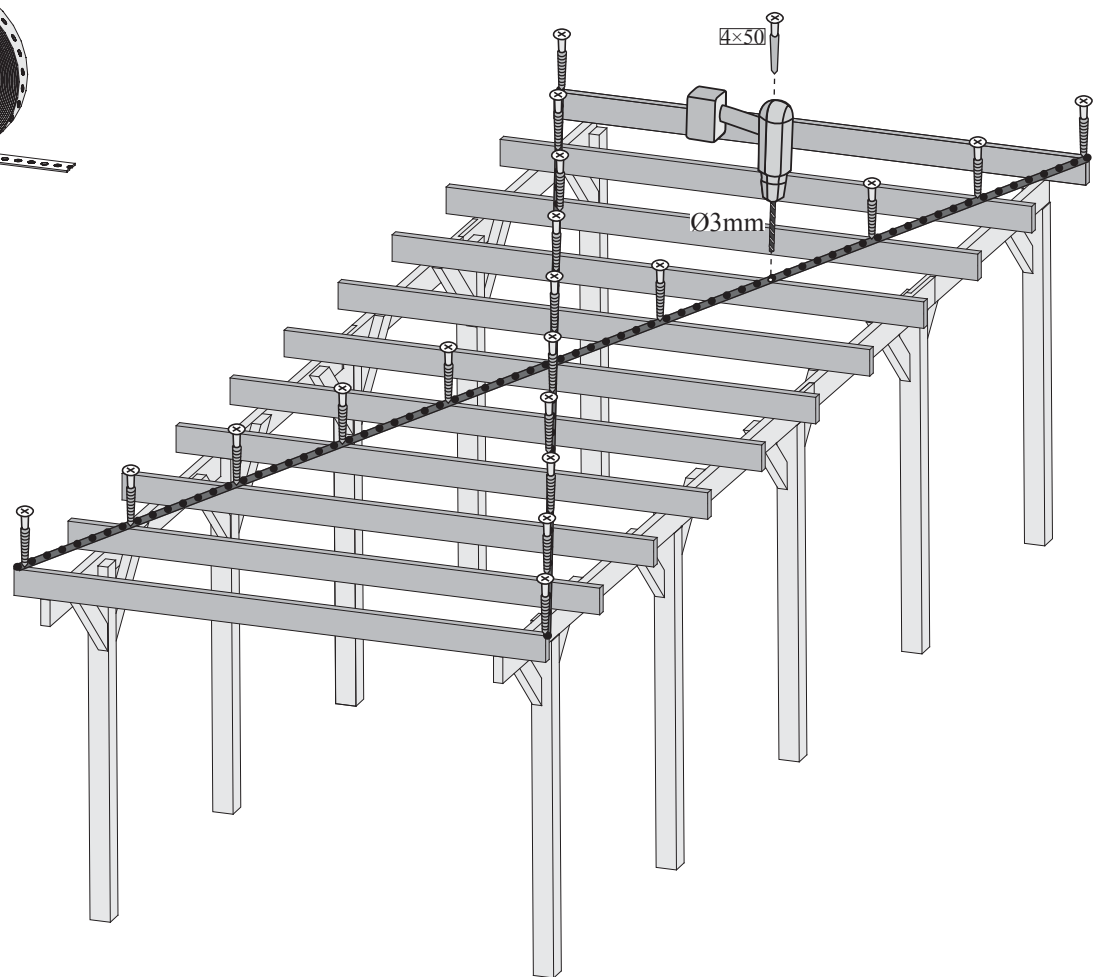
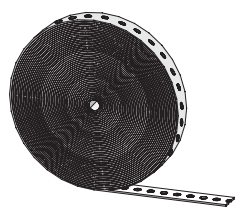

42 2x

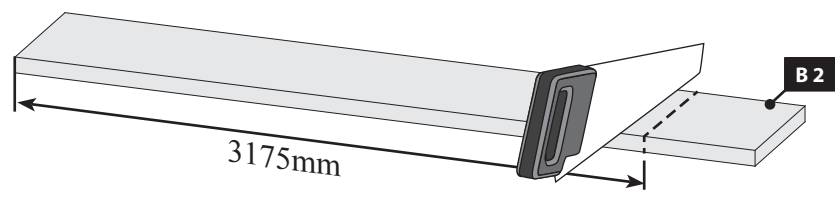

43 2x

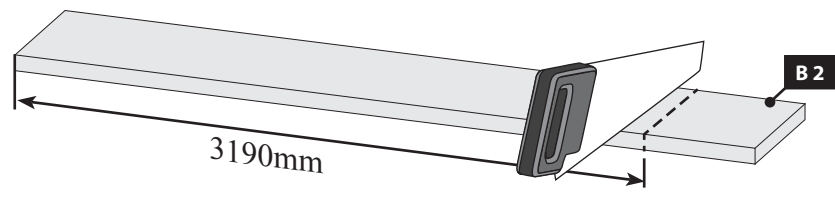

44 2x

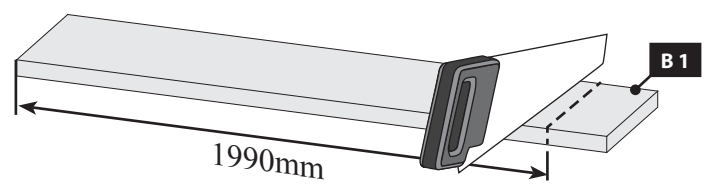

45

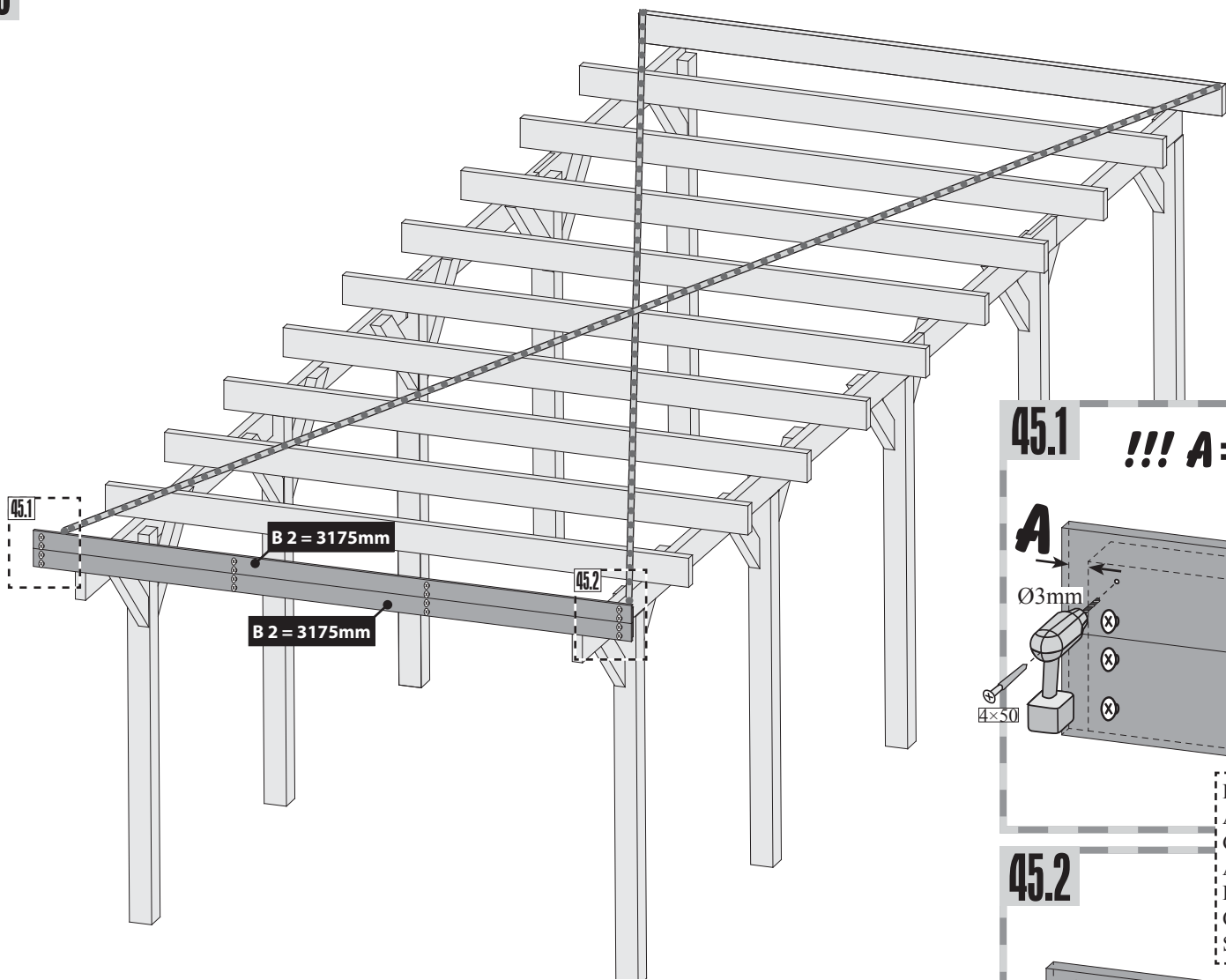

45.1 !!! A=B !!!

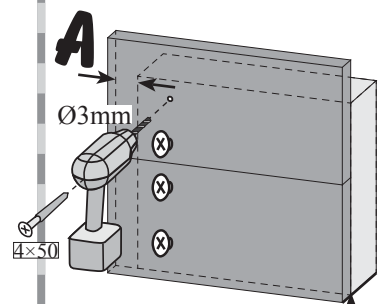

Bündig!
Affleurement!
Gelijk!
Aras!
Flush!
Combacia!
Stejný!

45.2

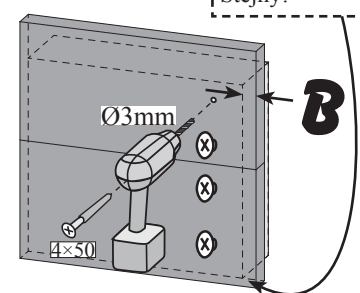

!!! A=B !!!



46

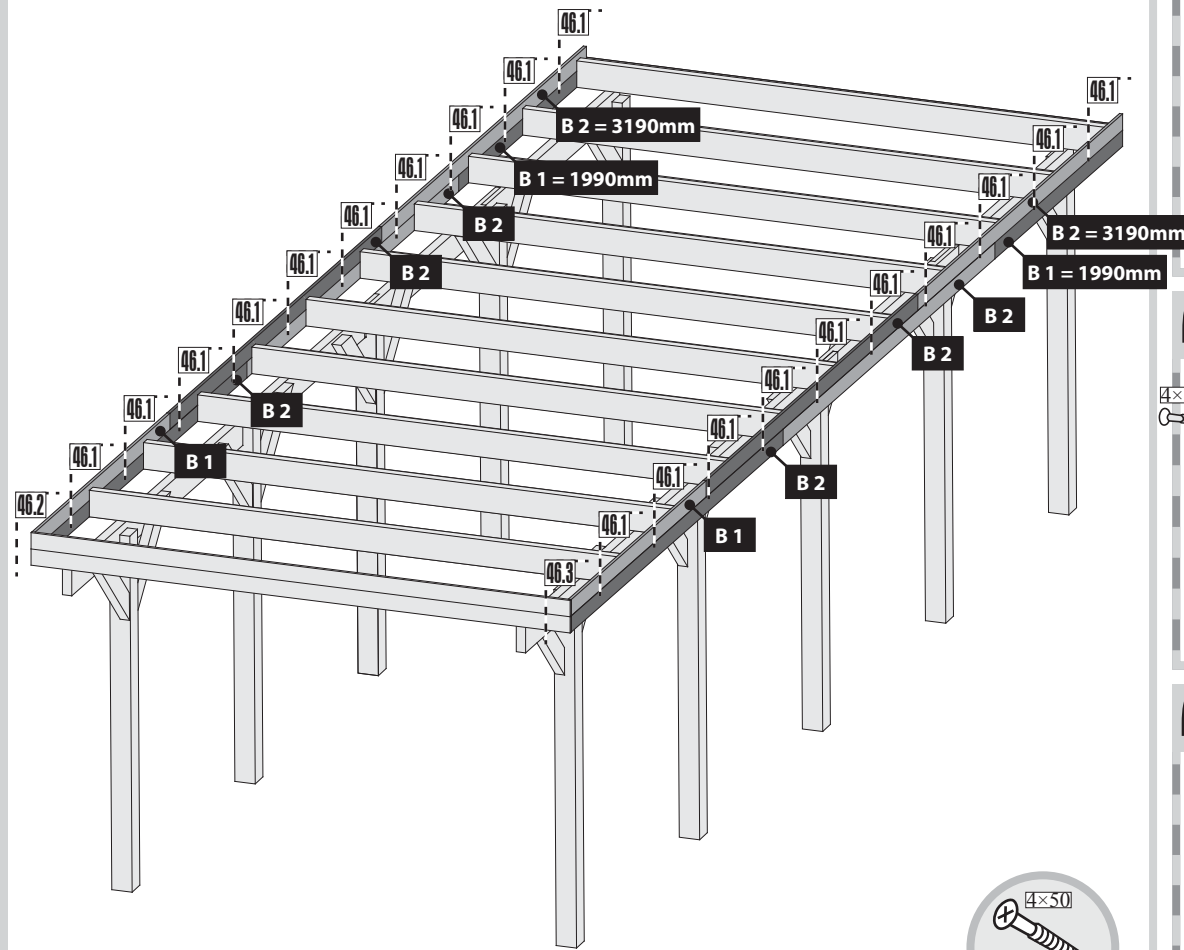

46.1

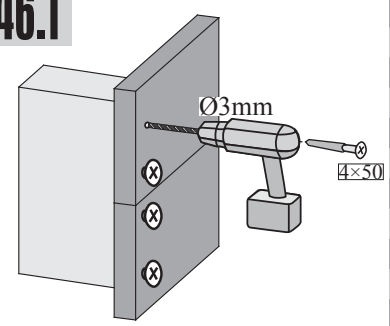

46.2

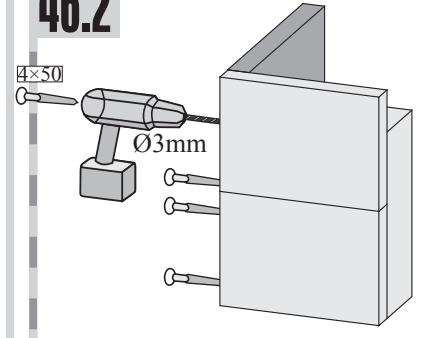

46.3

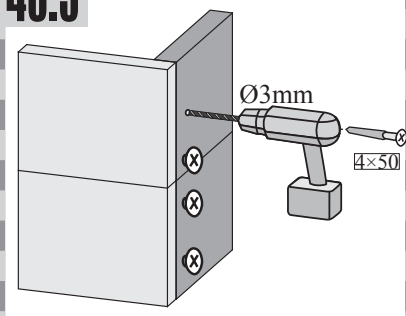

47

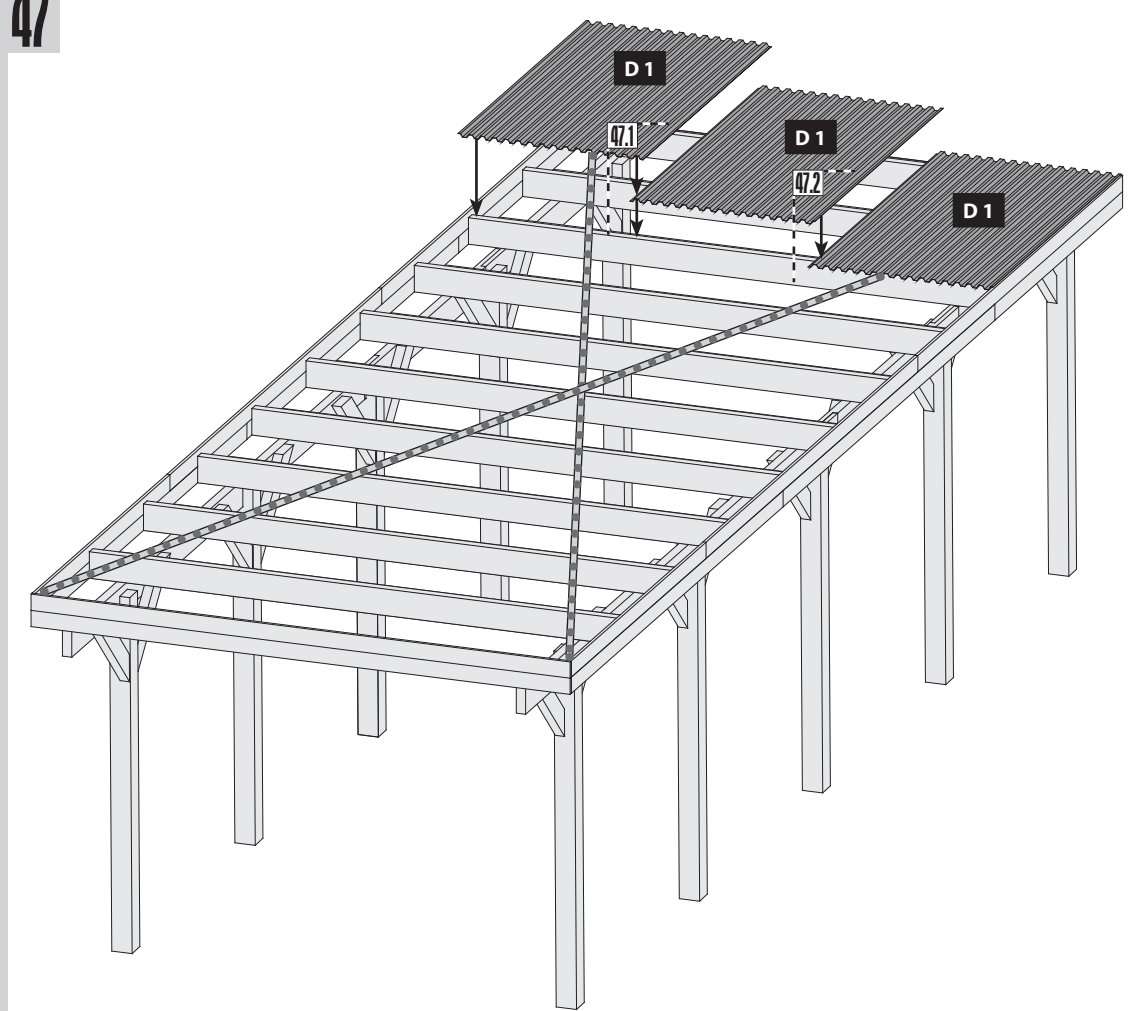

47.1

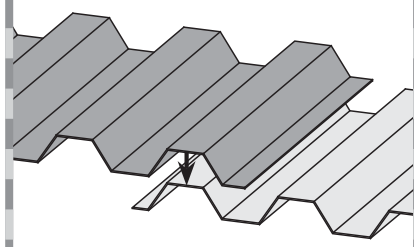

47.2

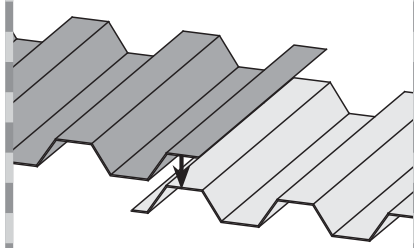

48

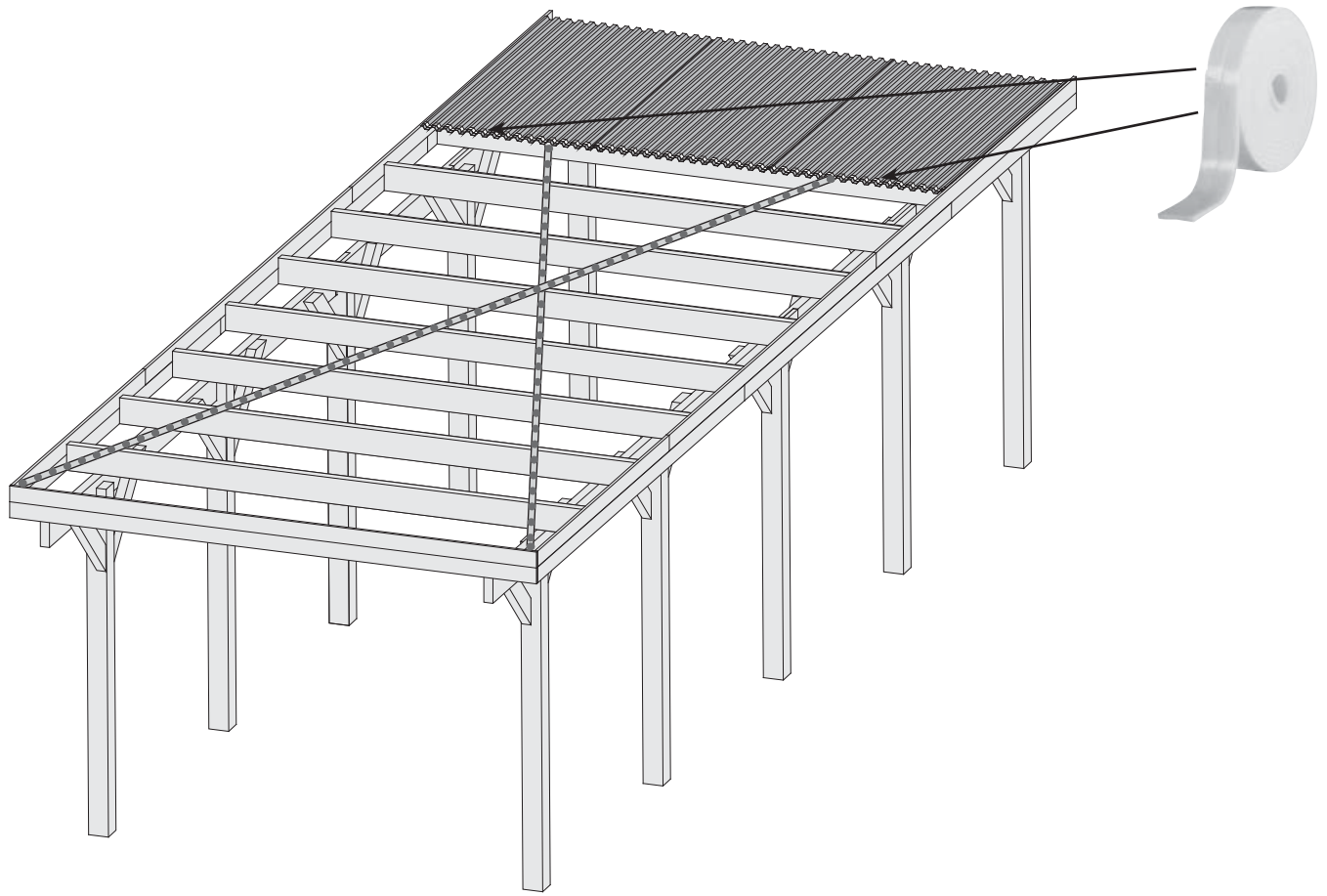

49

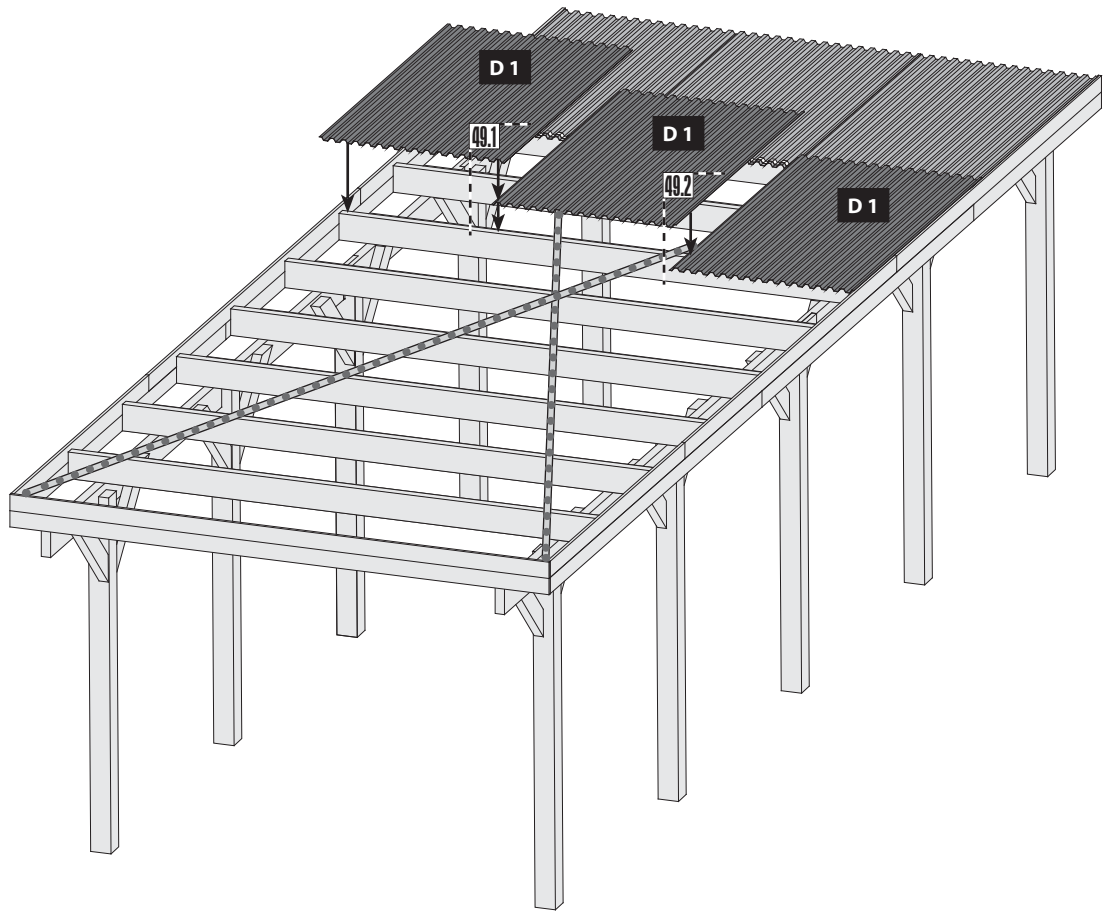

49.1

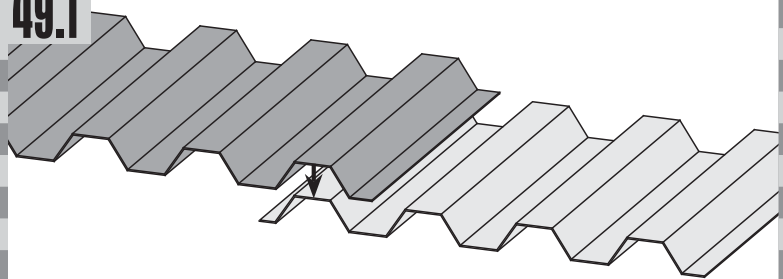

49.2

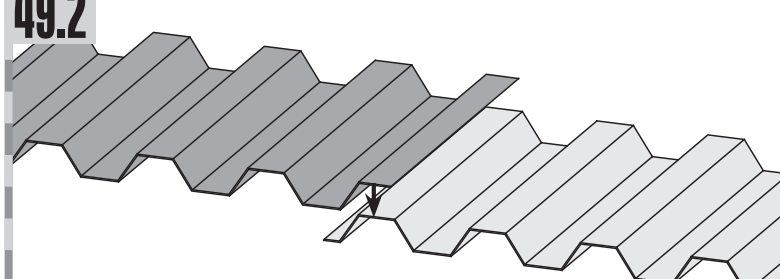

50

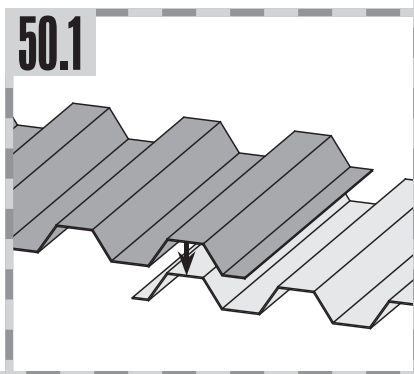
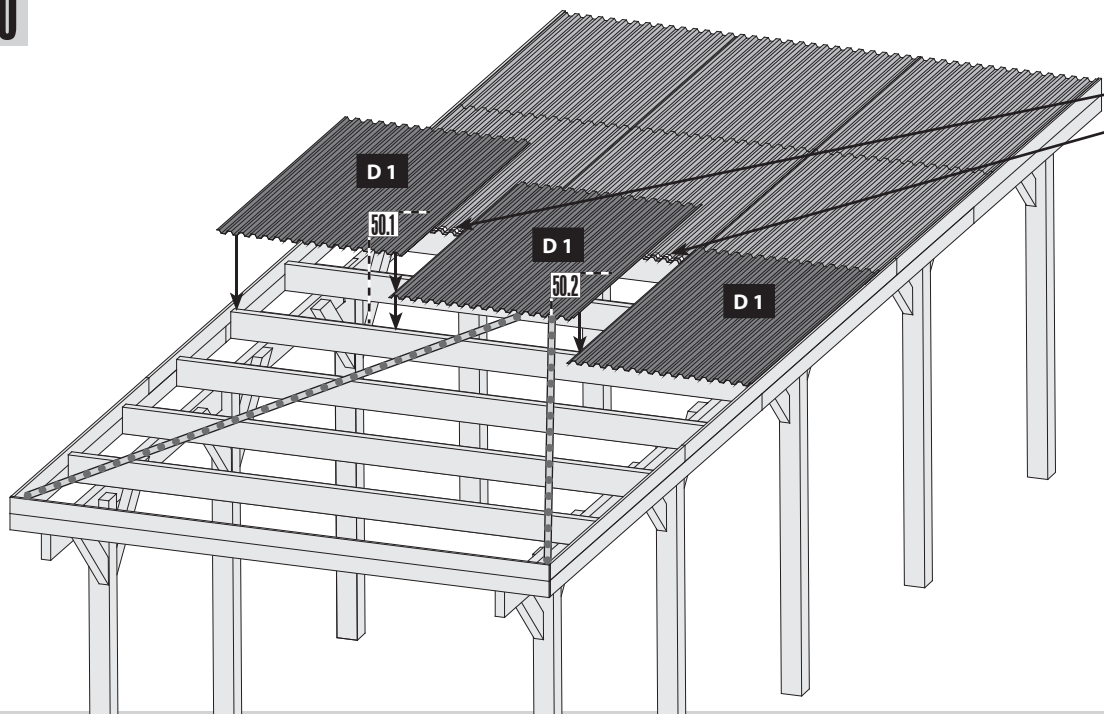

51

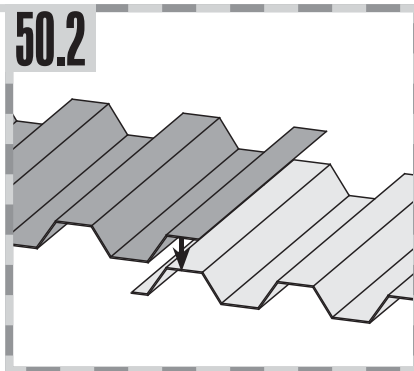
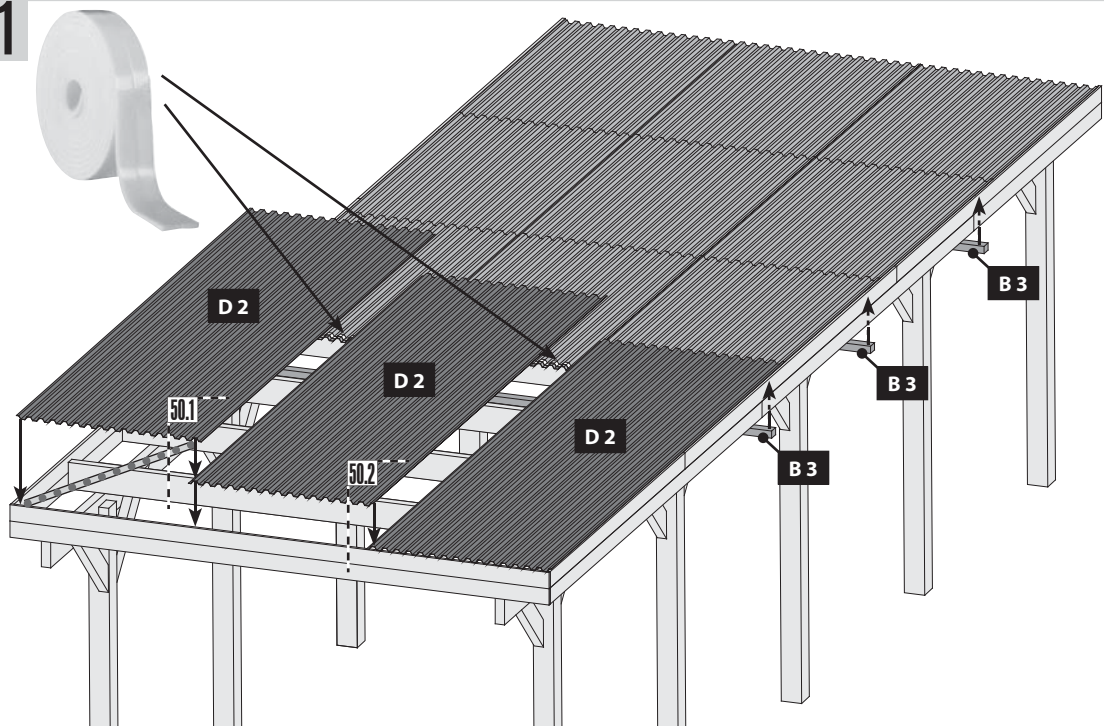

52

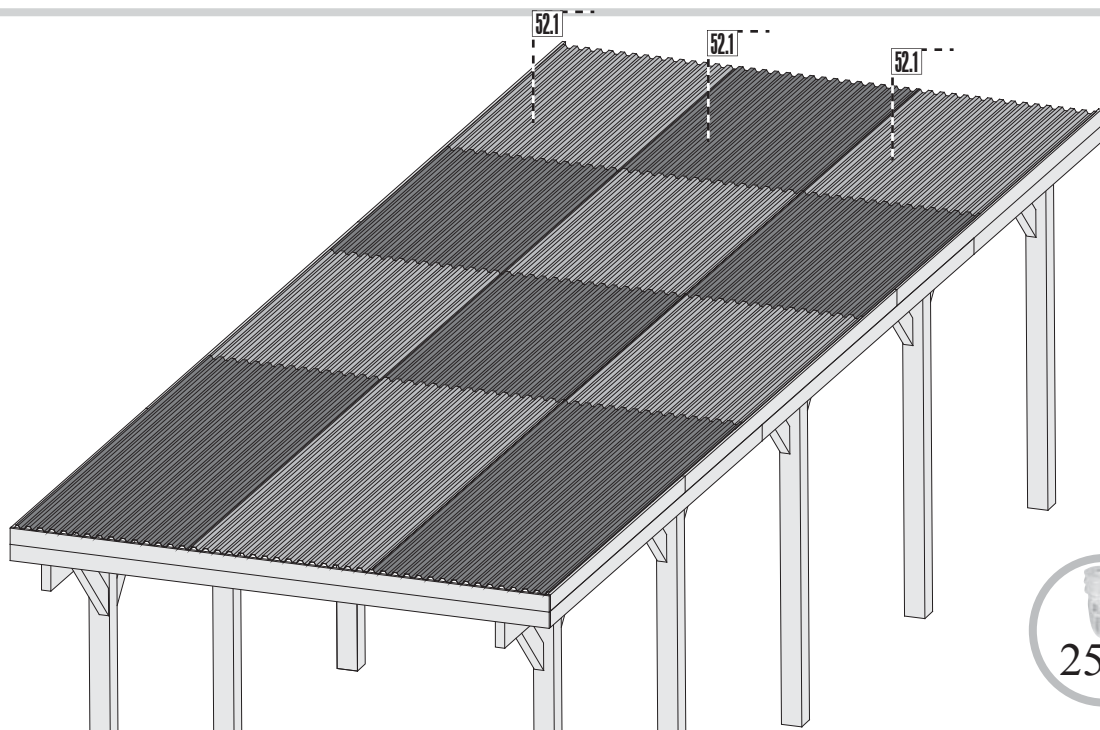

52.1

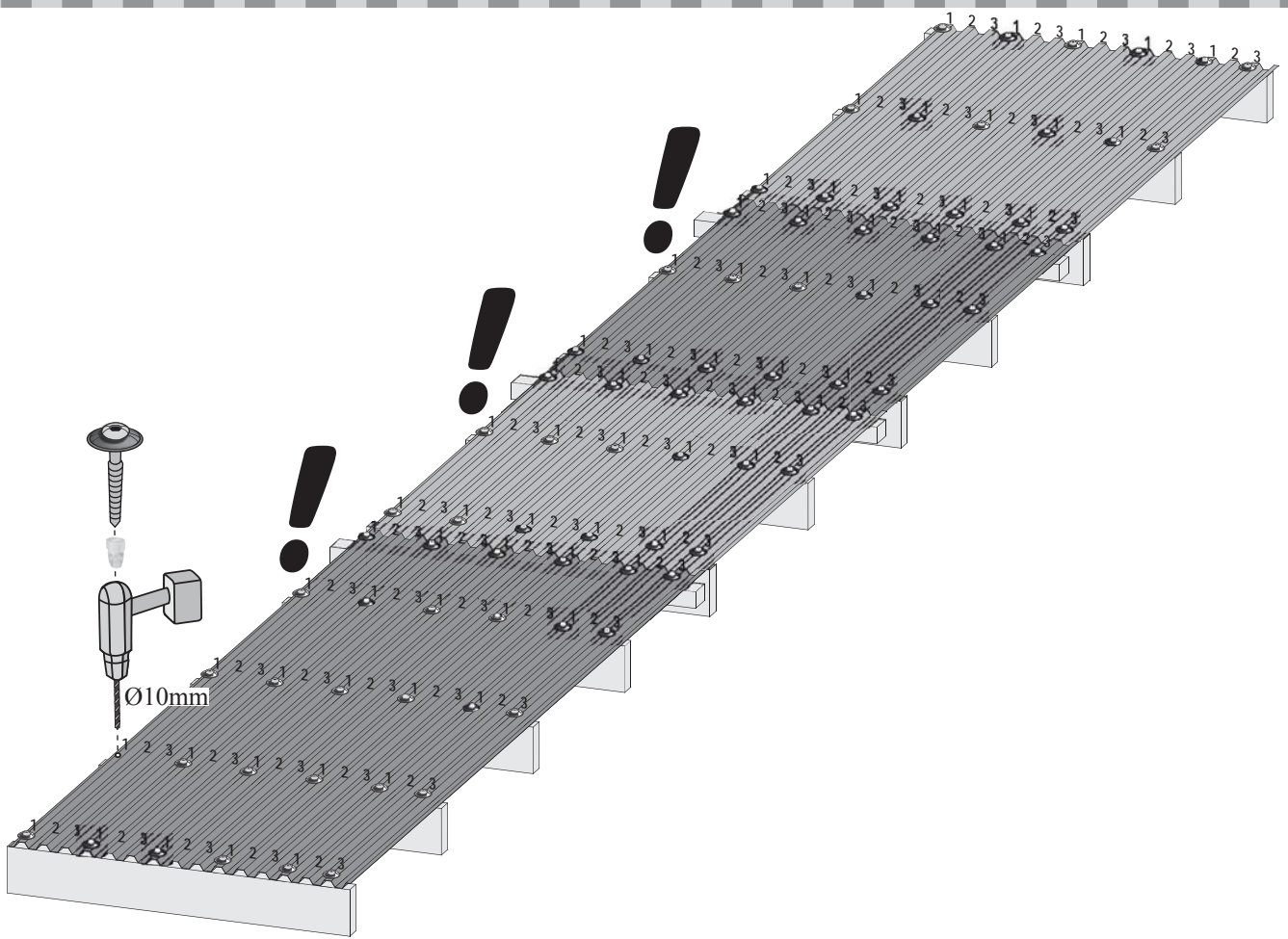



52.1-2

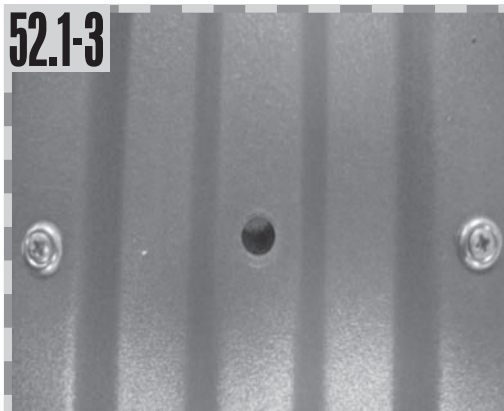

 Abstandshalter und Schrauben auf der Bedachungsplatte ablegen

52.1-3



 10mm Bohrloch mit Metall- oder Holzbohrer in die Bedachungsplatte vorbohren

52.1-4

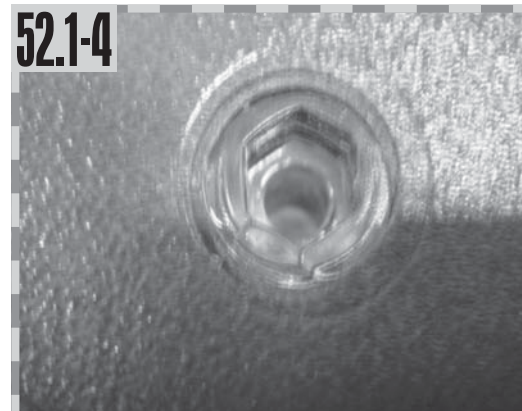

 Abstandshalter zB mit einem Torx 20-Bit unter die Bedachungsplatte drehen

52.1-5

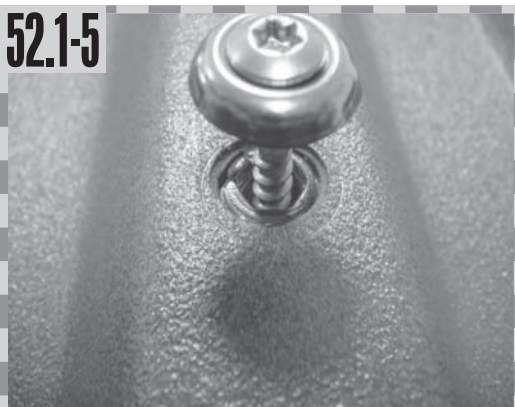

 Spenglerschraube setzen...

52.1-6

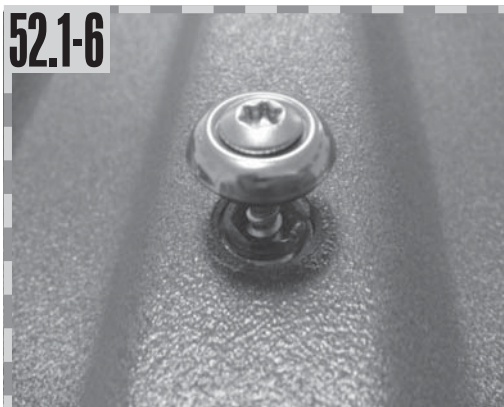

 ... und mit demselben Torx 20-Bit einschrauben...

52.1-7

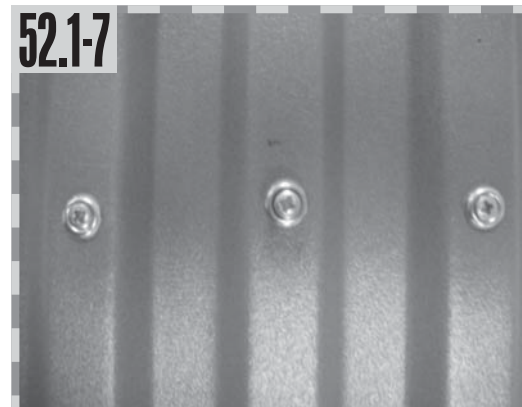

 ... und ohne Zwängung fixieren.
Fertig!

Lagerung

Prüfen Sie genau Ihre gelieferte Ware, spätere Reklamationen können nicht anerkannt werden.

Bitte beachten Sie diese Lagerungs- und Verarbeitungshinweise. Bei Nichteinhalten keine Reklamationsansprüche!

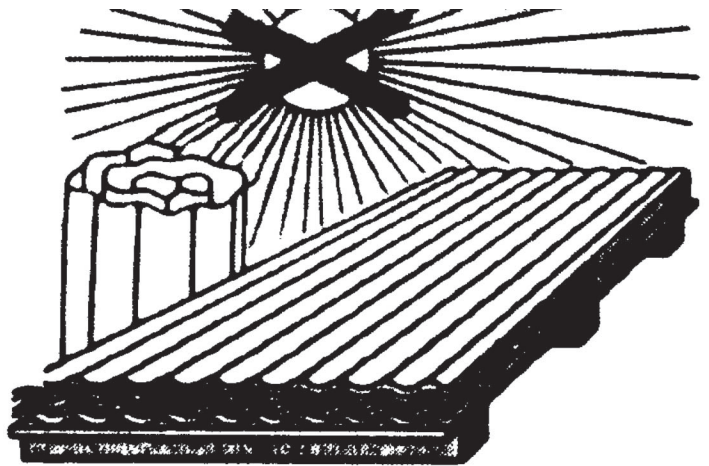

- Hitzestau und Nässe vermeiden.
- PVC-Tafeln dürfen im Stapel nicht dem Sonnenlicht und der Feuchtigkeit ausgesetzt werden. Es besteht Gefahr der Überhitzung (Brennglaswirkung!).
- Die maximale Lagerungstemperatur im Stapel darf 60°C nicht überschreiten. Für Brennglasschäden übernehmen wir keine Haftung.
- Auf ebener, nicht aufgeheizter Unterlage lagern und mit licht- und wasserundurchlässigen hellen Planen abdecken.
- Stapelhöhe max 50 cm
- Max Raumtemperatur: 40°C
- Während der Lagerung müssen PVC-Tafeln von Witterungseinflüssen, Verschmutzung und mechanischen Belastungen geschützt werden.

Montage

- Nicht bei Temperaturen unter 5°C durchführen.
 - Montagebedingte manuelle Transporte einzelner Platten nicht bei Wingschwindigkeit über 3m/s durchführen.
 - Bei der Montage von Doppelstegplatten ist die Wandanschlussseite mit einer Dichtung abzuschließen, sodass das Eindringen von Staub und Regenwasser verhindert wird.
- Aufgrund von verschiedenen Anbauoptionen ist das Dichtband nicht im Lieferumfang enthalten.

Reinigung

- Der Reinigungszyklus ist abhängig vom Verschmutzungsgrad, sollte jedoch von außen mindestens einmal jährlich erfolgen.
- Verschmutzungen mit Wasser oder Haushaltsreinigungsmitteln beseitigen.
- Keine scheuernden, ätzenden oder lösungsmittelhaltigen Zusätze verwenden.

Storage

Check your delivered goods with extreme care, as later complaints cannot be entertained.

Please observe these storage and processing instructions. In the event of a failure to observe these instructions, claims relating to complaints will not be entertained!

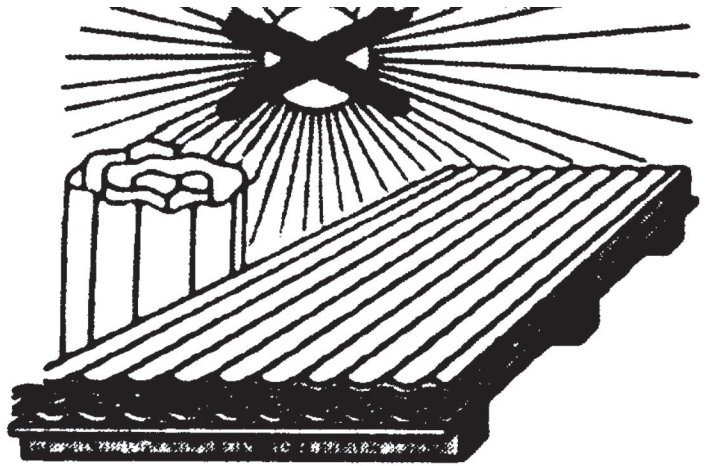

- Avoid heat accumulation and damp.
- Stacked PVC sheets should not be exposed to sunlight and moisture. A risk of overheating exists (risk of fire through focusing of solar radiation!).
- The maximum storage temperature when stacked should not exceed 60°C. We assume no liability for damage caused by the focusing of solar radiation in this manner.
- Store on a level, unheated surface and cover with bright tarpaulin impervious to light and water.
- Max. stack height 50 cm
- Max. room temperature: 40°C
- PVC sheets should be protected during storage against the effects of weather, dirt and mechanical loads or stress.

Installation

- Do not install at temperatures under 5°C.
 - Manual transportation of individual sheets necessary for installation should not be realised at wind speeds exceeding 3m/s.
 - When installing double-web sheets, the wall connection side should be fitted with a seal to prevent the penetration of dust and rainwater.
- Sealing tape is not included in the scope of delivery, due to the different attachment options involved.

Cleaning

- The cleaning cycle depends on the level of dirt, but exterior cleaning should be realised at least once a year.
- Remove dirt with water or a household cleaning agent.
- Do not use any scouring or caustic additives or additives containing solvents.

Stockage

Contrôlez la marchandise reçue avec précision, une réclamation ultérieure ne pourra être prise en compte.

Veuillez observer ces remarques sur le stockage et l'utilisation des plaques. Aucune réclamation ne pourra être acceptée en cas de non-respect !

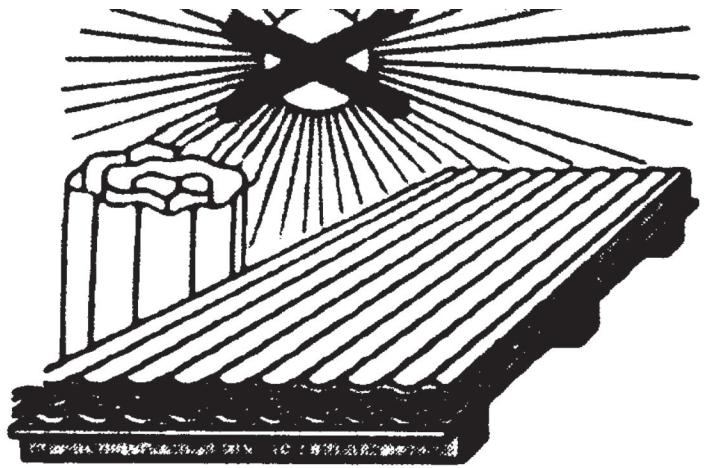

- Éviter l'accumulation de chaleur et l'humidité.
- S'ils sont empilés, les panneaux PVC ne doivent pas être exposés à la lumière du soleil ni à l'humidité. Risque de surchauffe (effet de loupe) !
- La température de stockage max. à l'intérieur de la pile ne doit pas dépasser 60 °C. Nous déclinons toute responsabilité en cas de dommages causés par un effet de loupe.
- Stocker sur une surface plane non chauffée et recouvrir de bâches claires opaques et imperméables à l'eau.
- Hauteur max. d'une pile : 50 cm
- Température ambiante max. : 40 °C
- Pendant le stockage, les panneaux PVC doivent être protégés des intempéries, de la saleté et des contraintes mécaniques.

Montage

- Ne pas réaliser le montage si la température est inférieure à 5 °C.
 - Ne pas effectuer le transport manuel de plaques individuelles nécessaire lors du montage si la vitesse du vent est supérieure à 3m/s.
 - Lors du montage de plaques alvéolaires, obturer le côté de raccordement au mur avec un joint pour empêcher la poussière et l'eau de pluie de pénétrer.
- En raison des différentes options de montage existantes, le ruban d'étanchéité n'est pas inclus dans la livraison.

Nettoyage

- La fréquence de nettoyage est fonction du degré d'encrassement. Au moins un nettoyage extérieur par an est toutefois recommandé.
- Nettoyer les plaques avec de l'eau ou des produits ménagers.
- Ne pas ajouter d'agents abrasifs, corrosifs ou à teneur en solvants.

 H-Pfostenanker montieren

 Ancres de béton installer

 Install concrete anchors

 Betonankers installeren

 Anclas concretas instalar

 Ancora di calcestruzzo installare

 Instalovat betonové kotvy

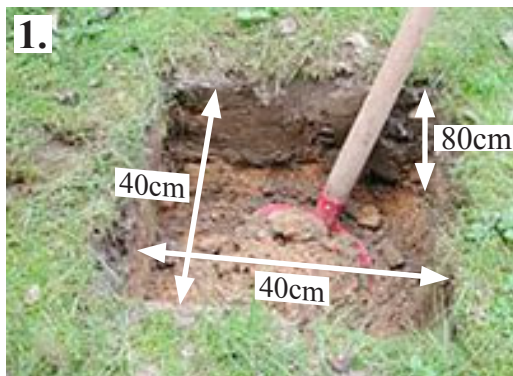

Eine Grube für jeden Pfosten ausheben.

Creusez un trou pour chaque montant.

Dig a hole for each column.

Een put voor elke staander graven.

Cavar un agujero por cada poste.

Creare un foro per ogni montante.

Jáma pro každé pracovní místo dig.



Der H-Pfostenanker kann auf dem Brett in seiner Lage noch verändert werden.

Les parties métalliques inférieures des montants peuvent encore être ajustées en fonction de leurs position respective sur les liteaux.

The position of the column joists can be altered due to their position on the plank.

De staanderdraggers kunnen door de positie op de plank qua positie nog veranderd worden.

La posición de los portapostes puede variarse a su posición mediante la posición sobre la tabla.

Le parti metalliche possono essere ancora aggiustate in funzione della loro posizione rispettiva sopra la tavola.

H-post kotvy může být změněn na palubě na svém místě.



Das Holzprodukt aufstellen. Die Pfosten in die H-Pfostenanker stellen. Etwas Abstand zwischen Pfostenende und Metall lassen. Die Pfosten durchbohren um sie mit den H-Pfostenankern zu verschrauben.

Positionnez le pavillon. Placez les montants dans leurs parties métalliques inférieures. Percez les montants afin de pouvoir ensuite les fixer et les visser aux parties inférieures métalliques.

Position the pavilion. Insert the columns into the joists in the process. Drill holes in the columns in order to connect them to the joists by means of screws.

Het paviljoen opstellen. De staanders daarbij in de staanderdraggers stellen. Om de staanders met de dragers vast te schroeven, moeten de staanders doorgeboord worden.

Colocar el pabellón. Colocar los postes en los portapostes. Perforar los postes para poderlos atornillar con los portapostes.

Posizionare il padiglione. Piazzare i montanti nelle loro parti metalliche. Per collegare i montanti con le parti metalliche è necessario perforare i montanti.

Umístěte dřevěného výrobku. Sloupky v H-post kotvy zeptat. Nechá se vzdálenost mezi sloupky a koncem kovu. Sloupky propíchnout je s H-post kotvy, aby šroub.



Eine Maschinenschraube vorsichtig durch die Öffnung des H-Pfostenankers einschlagen bis sie auf der anderen Seite wieder austritt.

Introduisez doucement dans le trou de la partie métallique, à l'aide d'un marteau, une vis d'assemblage à écrou, et cela jusqu'à ce qu'elle apparaisse de l'autre côté.

Carefully drill a drill screw through the opening in the concrete anchor and into the wood until the screw comes out the other side.

Een machineschroef voorzichtig door de opening van het betonanker in het hout inslaan tot ze op de andere zijde naar buiten treedt.

Introducir por percusión cuidadosamente un bulón ordinario en la madera a través de la apertura del anclaje de hormigón hasta que salga por el otro lado. Después aplanar el hormigón.

Introdurre, facendo attenzione, una vite d'assemblaggio nel foro dell'ancora di calcestruzzo nel legno fino a quando essa non fuoriesce dall'altra parte.

Šroub stroj lehce otočit, až se objeví na druhé straně prostřednictvím otvoru v H-post kotvy.

 H-Pfostenanker montieren

 Ancres de béton installer

 Install concrete anchors

 Betonankers installeren

 Anclas concretas instalar

 Ancora di calcestruzzo installare

 Instalovat betonové kotvy



Die Schraube mit Mutter und 2 Unterlegscheiben fixieren.

Vissez et serrez les vis à l'aide de boulons.

Attach nuts to the screws.

De schroeven met moeren fixeren.

Fijar los tornillos con las tuercas.

Fissare le viti con l'aiuto dei bulloni.

Šroub s maticí nebo 2 podložkami opravit.



Füllen Sie Beton in das ausgegrabene Loch. Der H-Pfostenanker bleibt weiterhin mit der Leiste fixiert. Danach den Beton glattstreichen.

Remplissez les trous creusés à l'aide de béton. Les parties inférieures métalliques des montants doivent encore rester maintenues en place à l'aide des liteaux. Nivelez ensuite le béton.

Fill the holes you have dug with concrete. The concrete anchor remains attached to the slat. Then, smooth out the concrete.

Giet beton in de put. Het betonanker blijft verder met de lijst gefixeerd. Daarna de beton gladmaken.

Llene el agujero cavado con hormigón. El anclaje de hormigón continúa fijado con el listón.

Riempire il foro incavato con del calcestruzzo. L'ancora in calcestruzzo continua a rimanere fissata con il listello. Livellare in seguito il calcestruzzo.

Vyplnit beton do vykopané díry. H-post kotvy zůstane připevněna k baru. Poté, co beton hladké.



Fertig einbetonierter Pfosten.

Montant installé et bétonné.

The posts are completely set in concrete.

Klaar ingebetonneerde staander.

Poste hormigonado acabado.

Montante installato e gettato nel calcestruzzo.

Hotovo vybetonován příspěvek.

45598

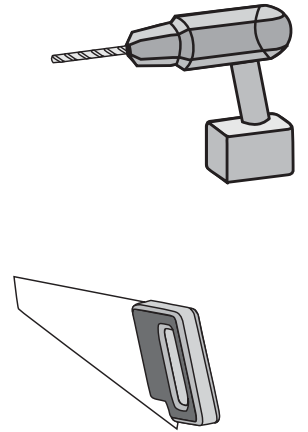
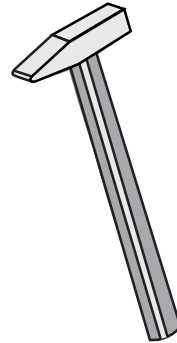
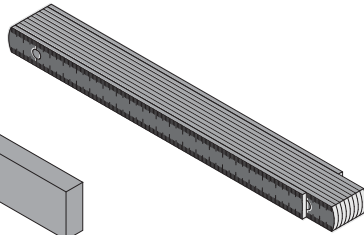
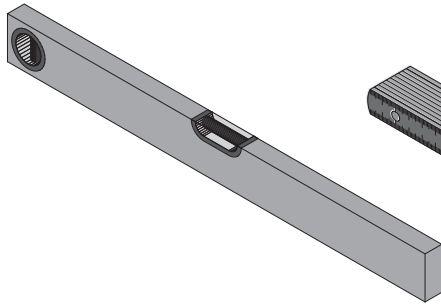
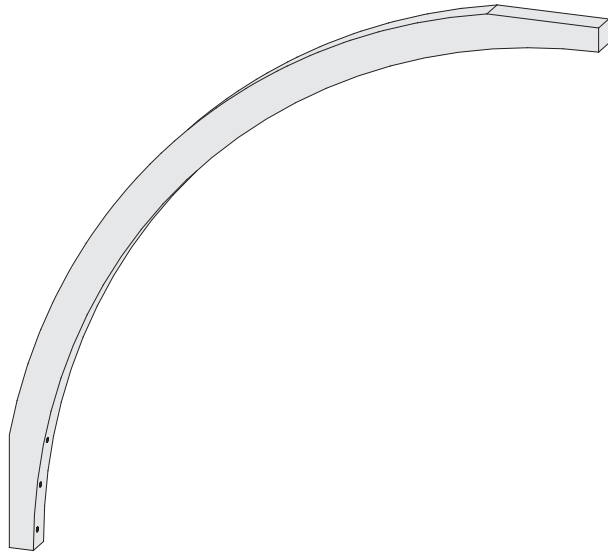

 **Aufbauanleitung**

 **notice de montage**

 **Building Instructions**

 **montagehandleiding**

 **Instrucciones de construcción**

 **Istruzioni per il montaggio**

 **Montážní návod**



Vergleichen Sie zuerst die Materialliste mit Ihrem Paketinhalt! Bitte haben Sie Verständnis, dass Beanstandungen nur im nicht aufgebauten Zustand bearbeitet werden können!



En primer lugar, compare la lista de material con el contenido del paquete. Rogamos entienda que las reclamaciones sólo pueden ser tramitadas antes de montar el objeto!



Nejprve přezkontrolujte obsah balení podle materiálového listu! Mějte pochopení pro to, že případnou reklamaci se můžeme zabývat pouze tehdy, když díly nebudou smontované! Za pomoci tohoto seznamu můžete jednotlivé díly přiřadit k montážnímu návodu.



Vergelijk eerst de lijst van materialen met de inhoud van uw pakket! Reclamaties kunnen alleen in behandeling worden genomen zolang de onderdelen nog niet zijn gemonteerd!



First compare the list of materials with your package contents! Please understand that complaints can be processed in the non-built status only!



Commencez par comparer la liste du matériel avec le contenu de votre paquet! Sachez que nous traitons uniquement les réclamations concernant le matériel à l'état non monté!



Confrontate questa distinta materiali prima con il contenuto del pacchetto! Vi preghiamo di comprendere che eventuali reclami possono essere accolti solo prima del montaggio!

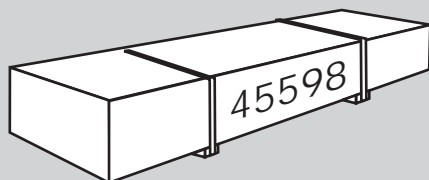



1 x	2800 x 115 x 115mm	ID 45774

1 x	220 x 12mm	ID 45775
1 x	240 x 12mm	ID 45777
2 x	260 x 12mm	ID 45779
1 x	280 x 12mm	ID 45781
10 x		ID 12010

3 x		ID 9253
-----	--	---------

 Dieses Produkt gibt es in verschiedenen Aufbauvarianten. Die Stückzahl- und Materialkontrolle sollte immer mit der dem Paket beigefügten Materialliste durchgeführt werden. Folgender Tabelle können Sie entnehmen, welche Anleitungsschritte mit welcher Nummer Sie zum Aufbau benutzen müssen. Orientieren Sie sich an der Anzahl der gelieferten Pakete und den Artikelnummern auf den Paketen.

 Dit product is er in verschillende opbouwvarianten. Het aantal stuks en de materiaalcontrole moet altijd met de bij het pakket gevoegde materiaallijst worden uitgevoerd. In de volgende tabel kunt u zien welke instructiestappen met welk nummer u voor het opbouwen moet volgen. Oriënteer u aan het aantal geleverde pakketten en aan de artikelnummers op de pakketten.

 Ce produit existe dans différentes variantes de montage. Le contrôle du nombre de pièces et du matériel doit toujours être effectué à l'aide de la liste du matériel jointe au paquet. Le tableau suivant vous indique quelles étapes de la notice avec quel numéro vous devez utiliser pour le montage. Veuillez vous orienter sur le nombre de paquets livrés et sur les numéros d'articles figurant sur les paquets.

 Existen distintas variantes de combinaciones de construcción de este producto. El control de la cantidad y del material siempre debería ser realizado con la lista del material adjunta al paquete. En la tabla siguiente puede obtener la información del número que debe utilizar con cada etapa de las instrucciones para la construcción. Oriéntese mediante el número de paquetes suministrados y los números de artículos sobre estos.

 This product is available in different construction variants. Always control the numbers and materials on the basis of the material list included with the package. The following table shows which instruction corresponds to which number during assembly of the construction. Construction is oriented to the number of packages supplied and the article numbers shown on the packages.

 Questo prodotto è disponibile in diverse varianti. Il controllo del numero di pezzi e del materiale va eseguito sempre con la distinta dei materiali allegata al pacchetto. Dalla seguente tabella si può dedurre quali istruzioni per l'uso (indicate con i relativi codici) si devono utilizzare per il montaggio. Ci si può orientare basandosi sul numero di pacchetti consegnati e sul codice articolo riportato sui pacchetti stessi.

 Tento produkt je k dispozici v různých tělesných variantách. Počítat kus a kontrolní materiál by měl být vždy provedeno s dokumenty příloženými k seznamu obalový materiál. Následující tabulka ukazuje, které ruční kroky, které číslo je nutné použít stavět. Orientovat se na počtu balíků dodaných a čísla článků na obalech.

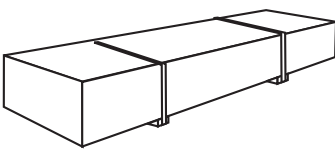

1x ID 61576/61581 + 1x ID 45598

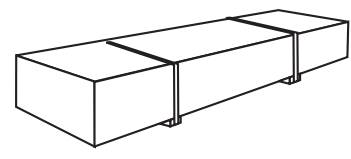
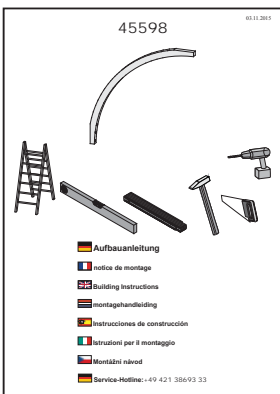
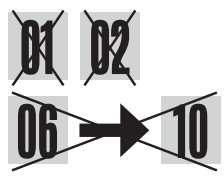
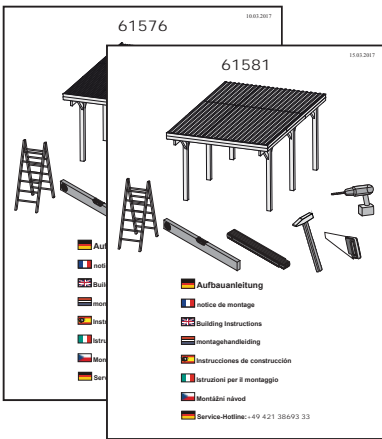
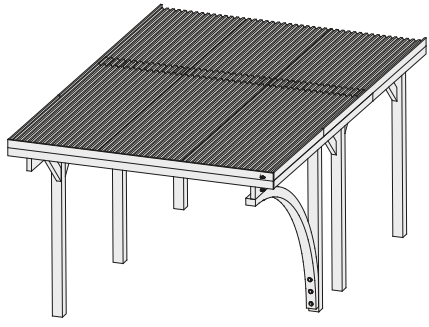

1x ID 61576/61581 + 1x ID 61579/61583
1x ID 45598

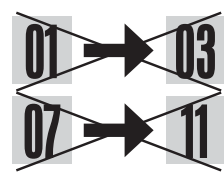
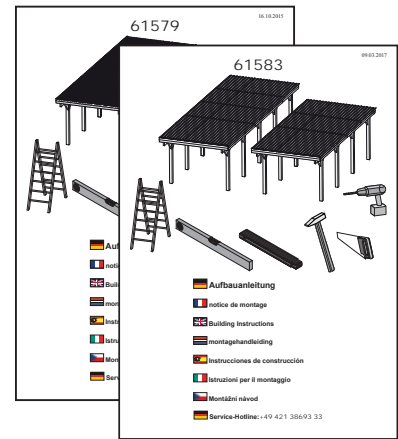
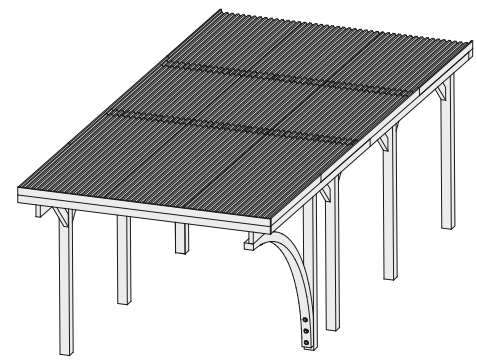

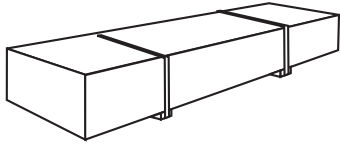

1x ID 61576/61581 + 2x ID 61579/61583
1x ID 45598

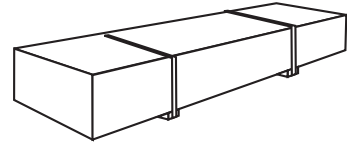
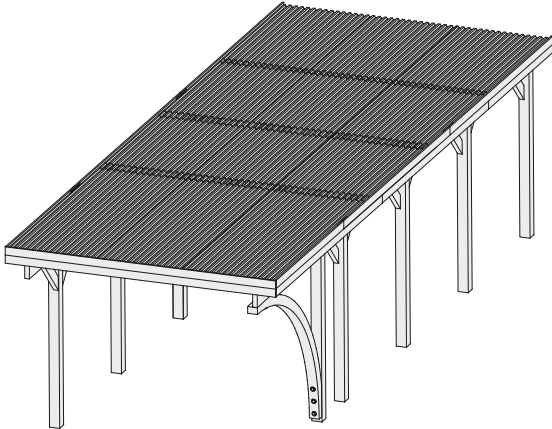

1x ID 61585/61589 + 1x ID 45598

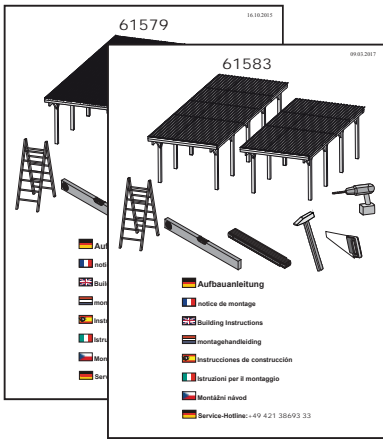
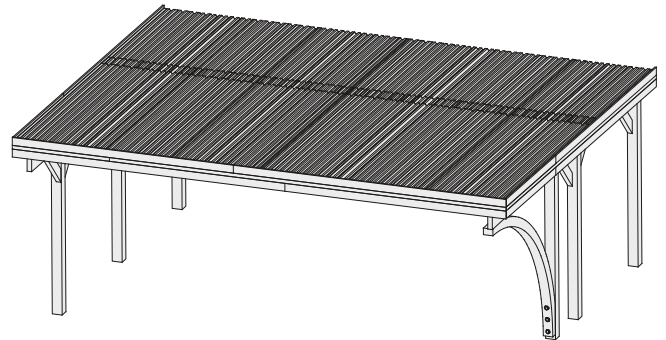

~~27~~ → ~~30~~
~~34~~ → ~~38~~

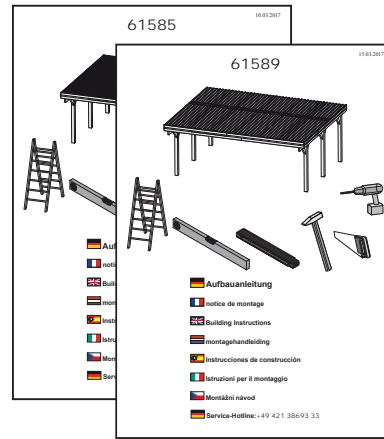

~~01~~ ~~02~~
~~06~~ → ~~10~~

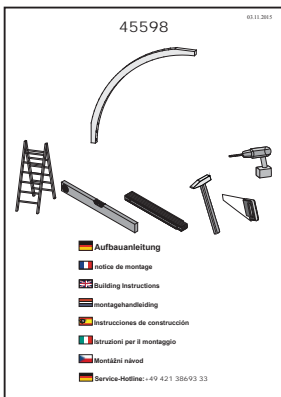

27c → 30c 34c
35c 08d → 09d

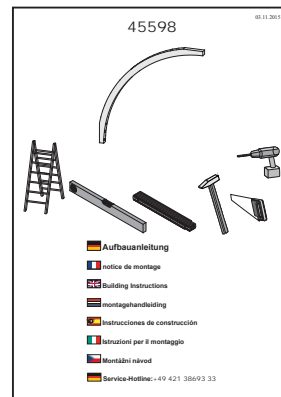

01a 02a 06a
07a 08d → 09d

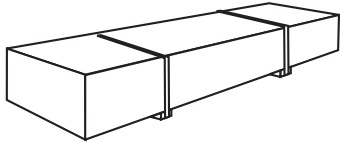

1x ID 61585/61589 + 1x ID 61587/61591
1x ID 45598

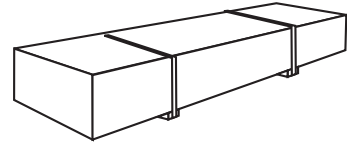
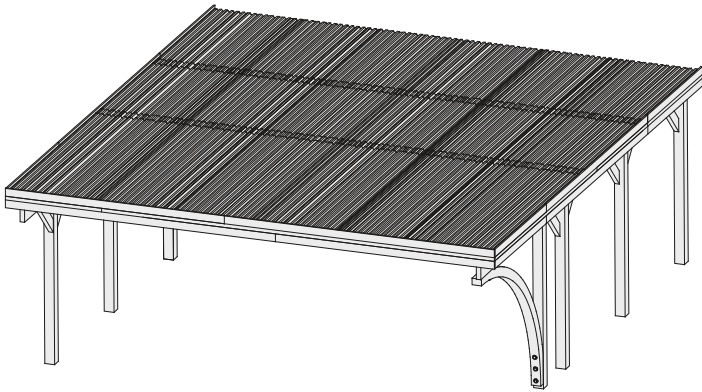

1x ID 61585/61589 + 2x ID 61587/61591
1x ID 45598

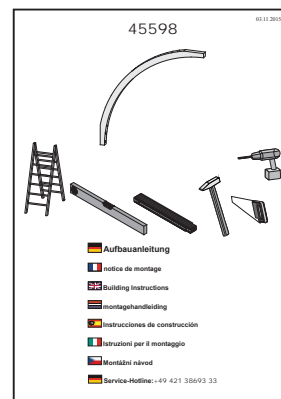
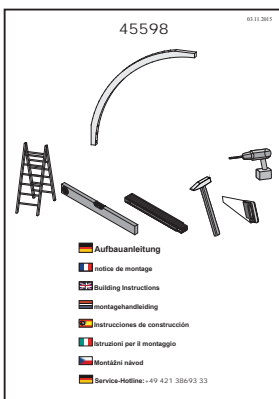
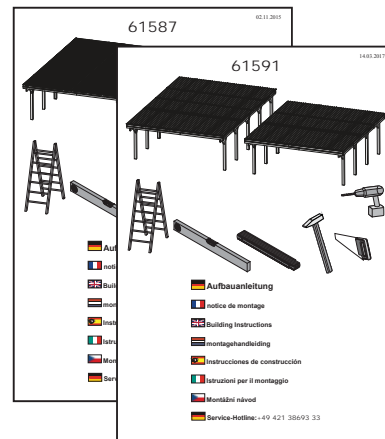
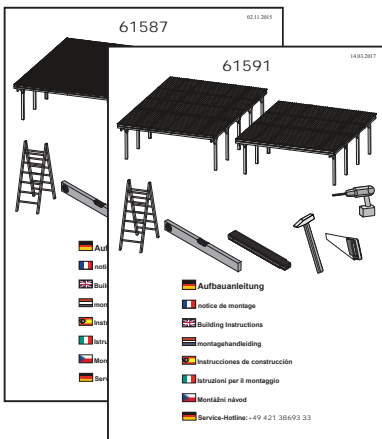
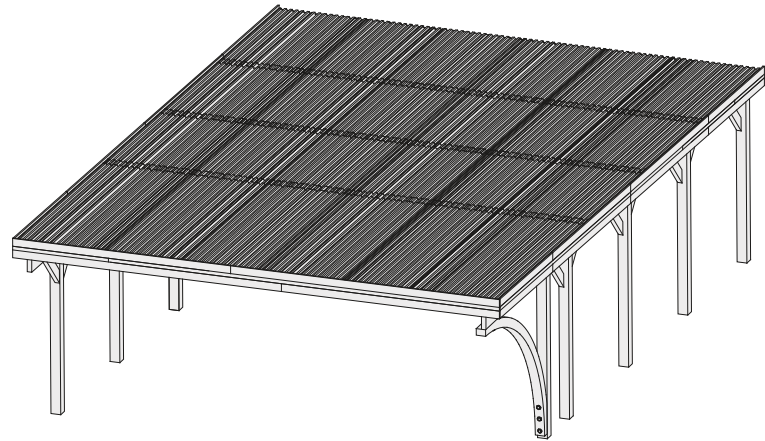

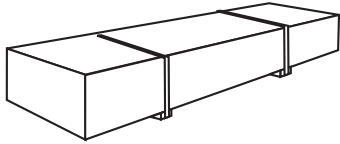

1x ID 61576/61581 + 1x ID 61593
1x ID 45598

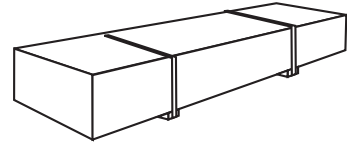
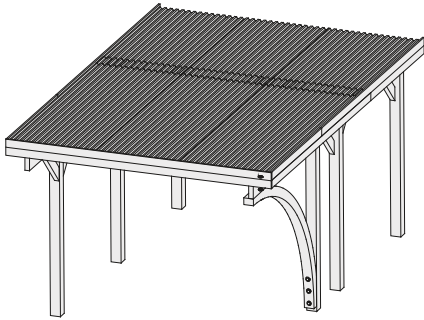

1x ID 61576/61581 + 1x ID 61579/61583
1x ID 61593 + 1x ID 61595 + 1x ID 45598

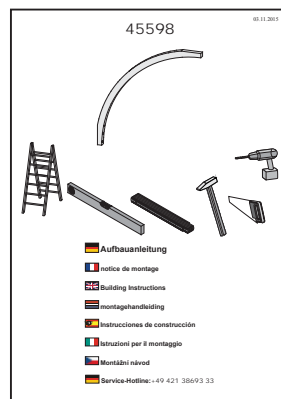
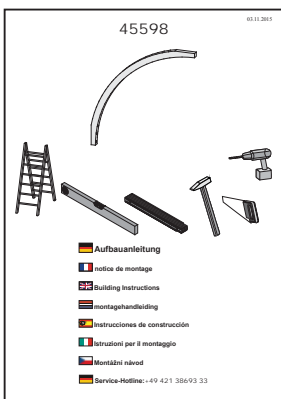
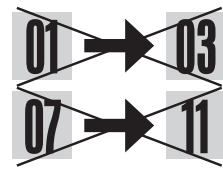
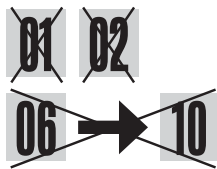
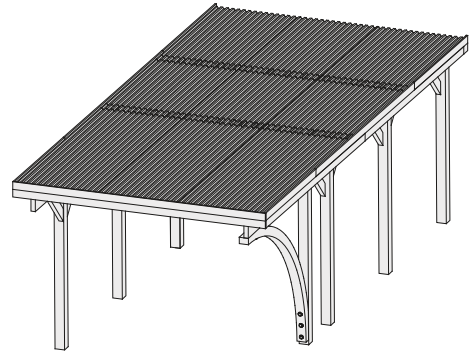

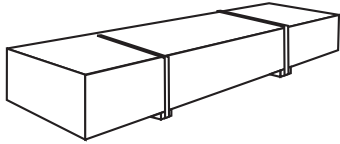

1x ID 61576/61581 + 2x ID 61579/61583
 1x ID 61593 + 2x ID 61595 + 1x ID 45598

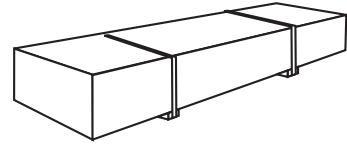
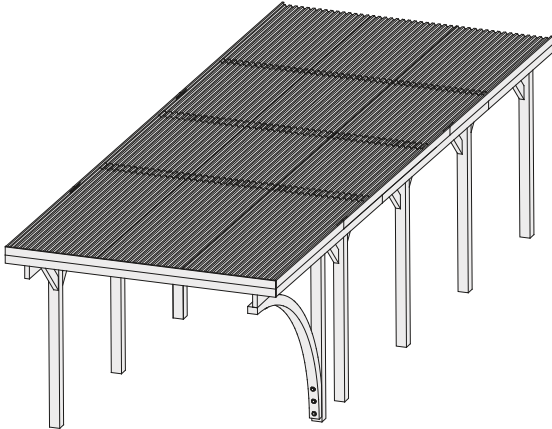

1x ID 61585/61589 + 1x ID 61597
 1x ID 45598

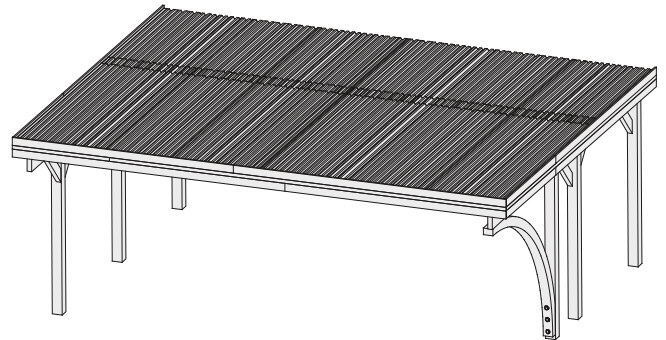

~~22~~ → ~~25~~
~~29~~ → ~~33~~



~~01~~ ~~02~~
~~06~~ → ~~10~~



27c → 30c 34c
 35c 08d → 09d

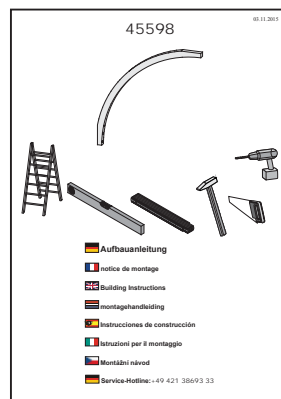

01a 02a 06a
 07a 08d → 09d

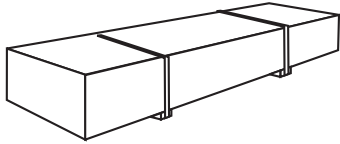

1x ID 61585/61589 + 1x ID 61587/61591
 1x ID 61597 + 1x ID 61599 + 1x ID 45598

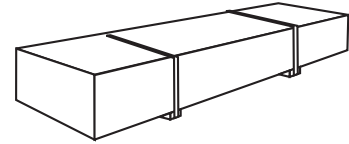
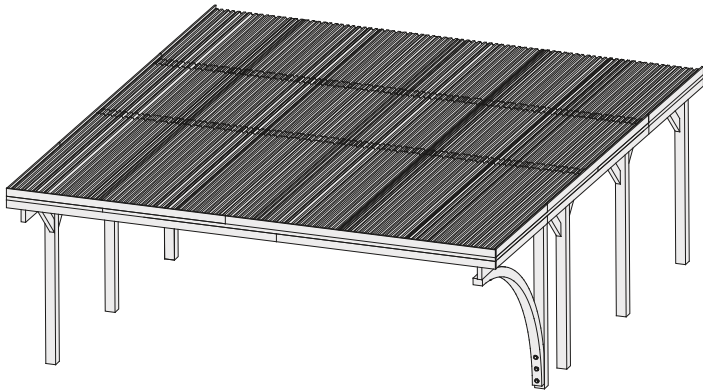

1x ID 61585/61589 + 2x ID 61587/61591
 1x ID 61597 + 2x ID 61599 + 1x ID 45598

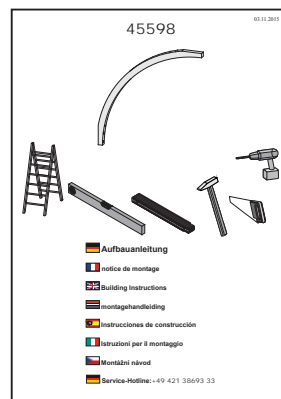
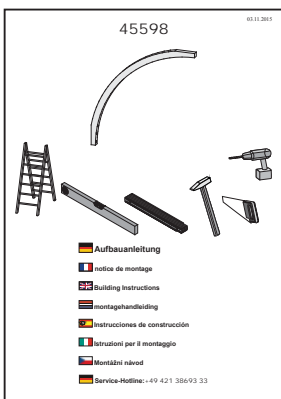
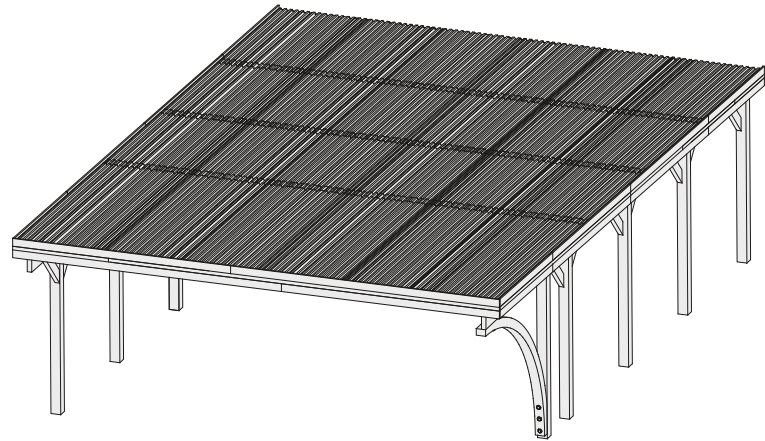

01a 2x

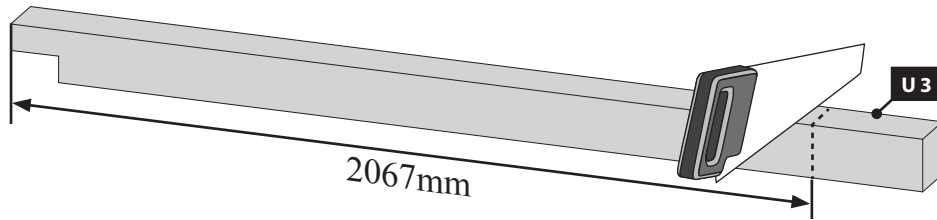

02a 2x

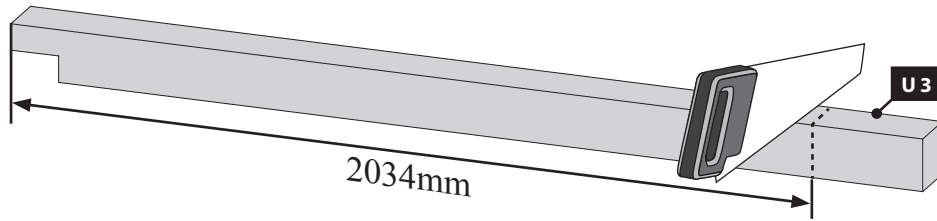

1x

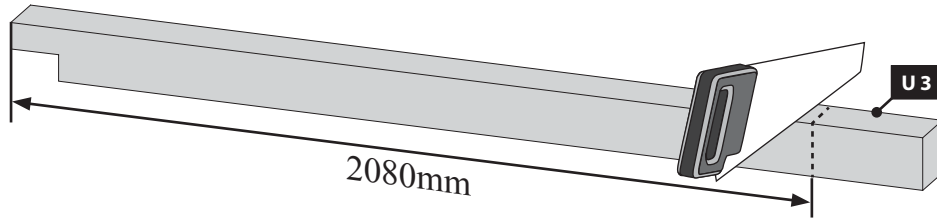

06a

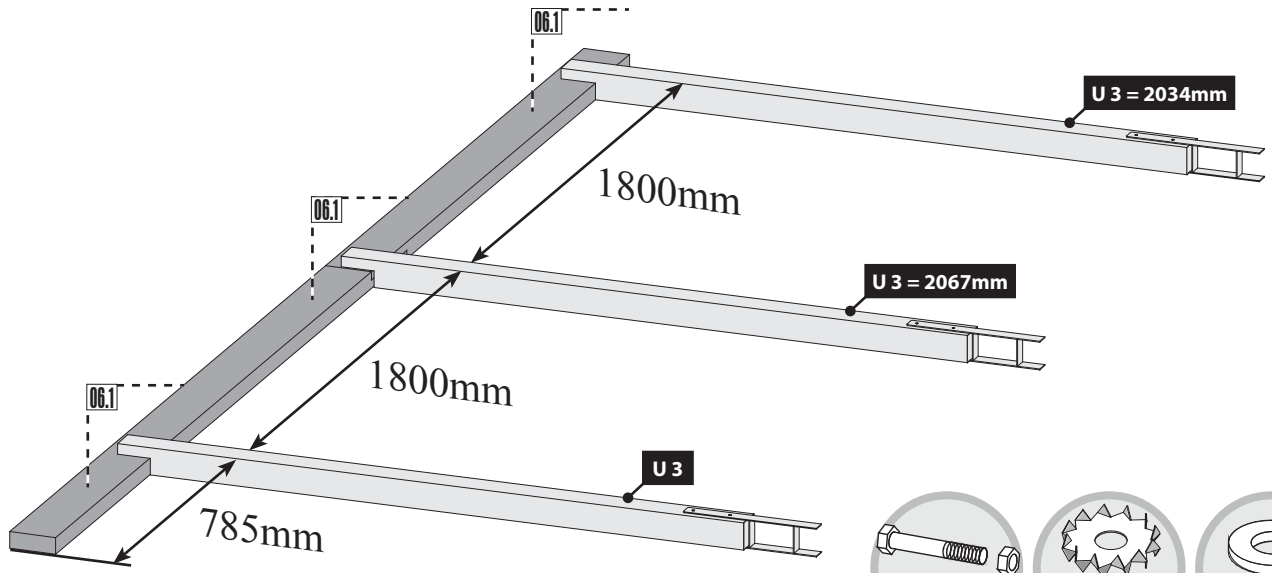

07a

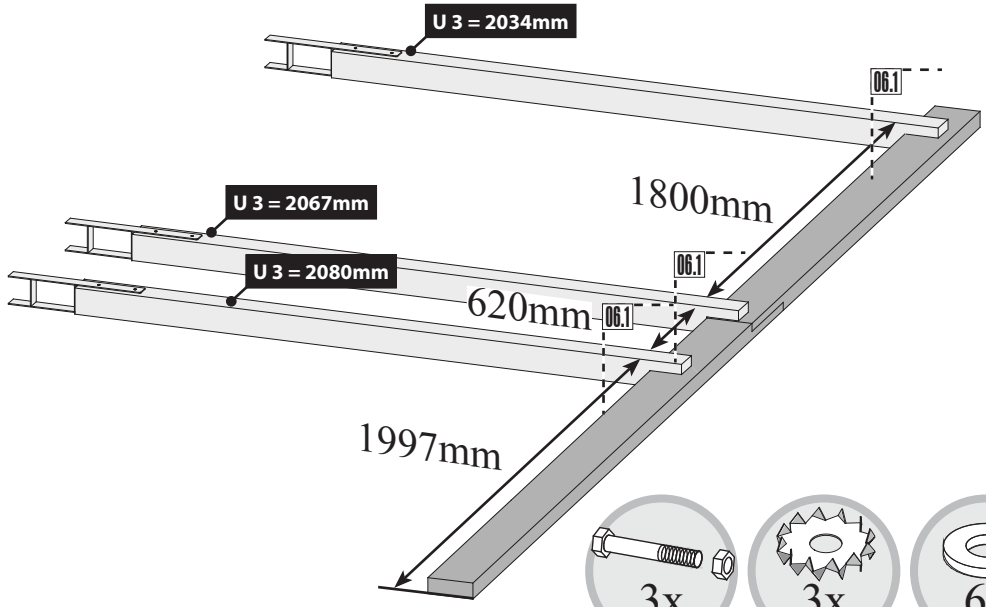

06.1

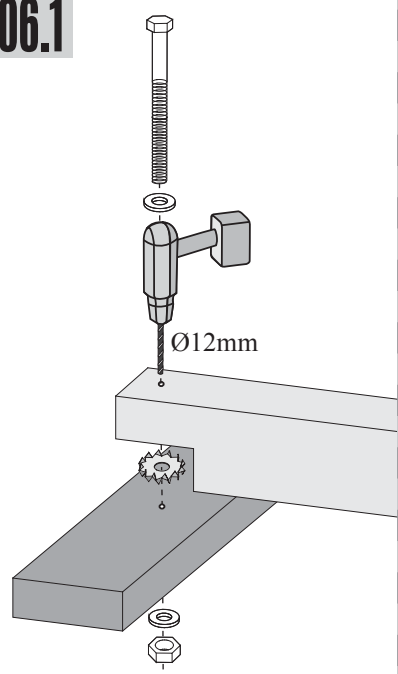

01b 2x

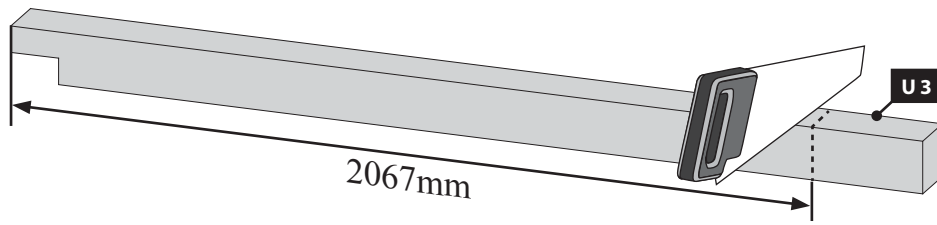

02b 2x

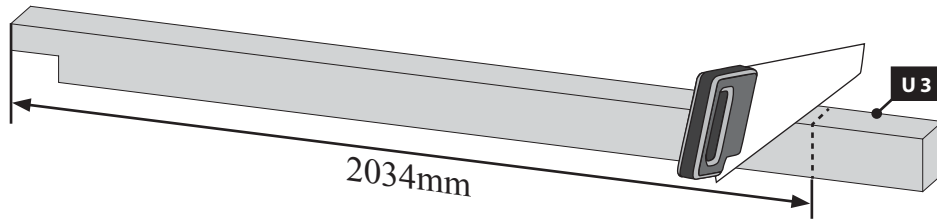

03b 2x

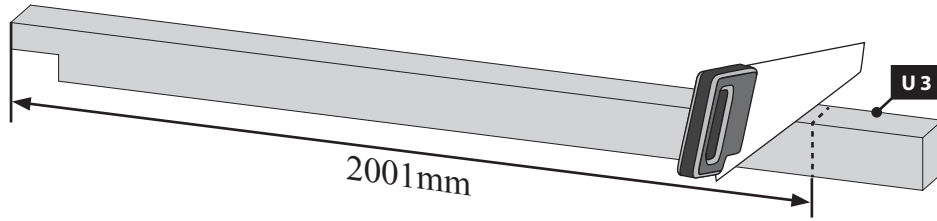

1x

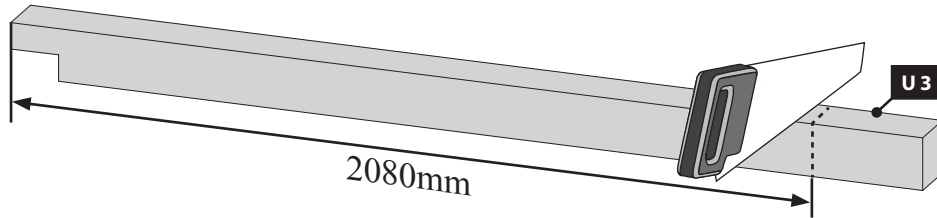

07b

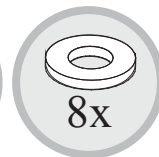
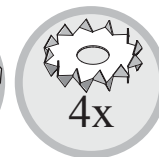
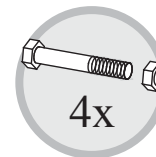
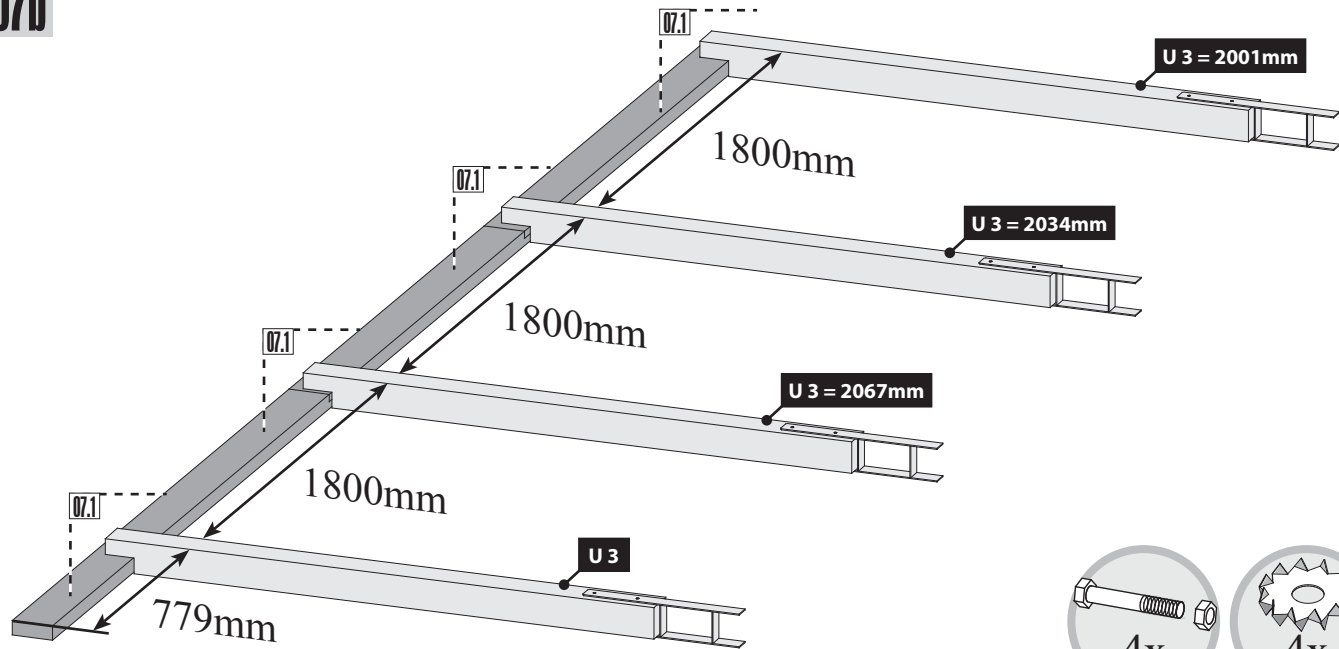

08b

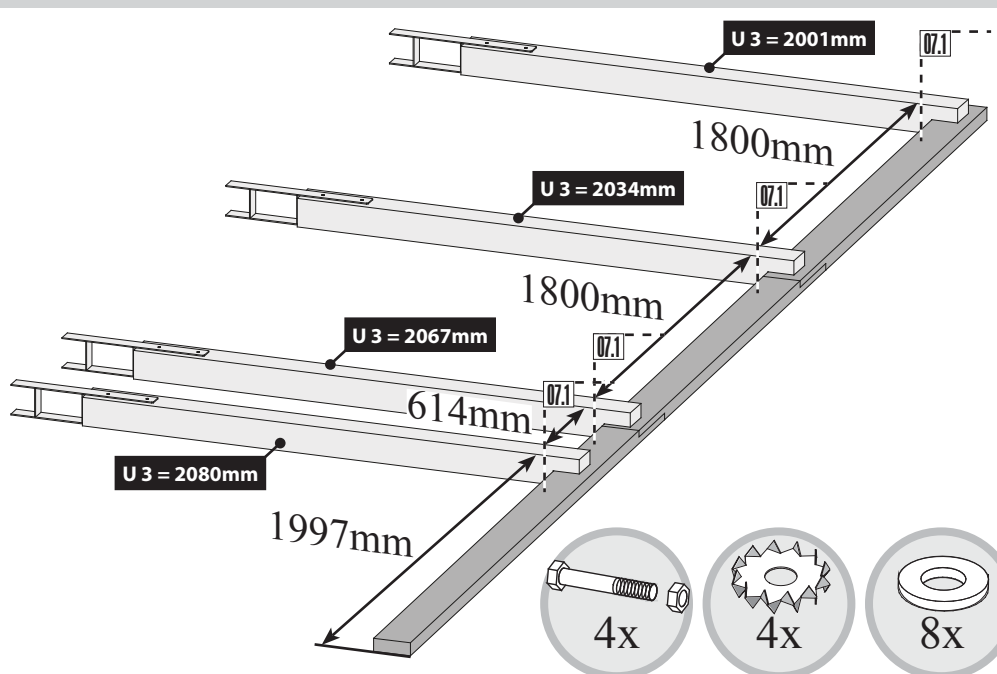

07.1

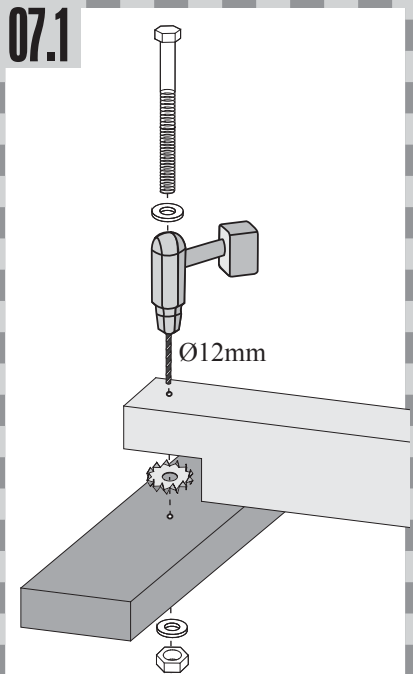

27c 2x

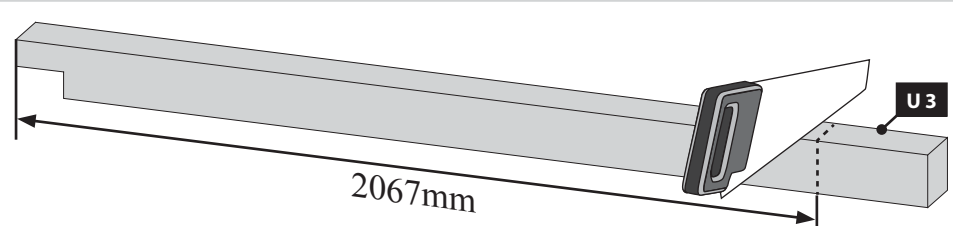

28c 2x

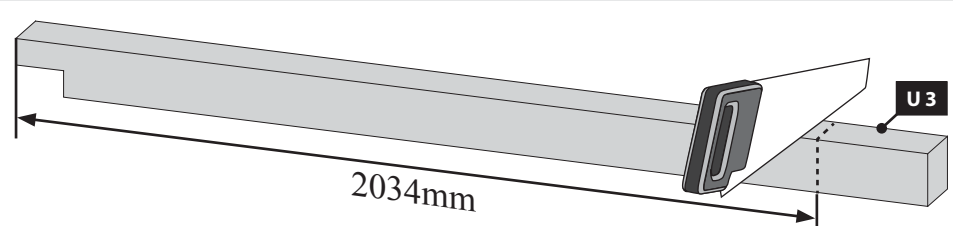

29c 2x

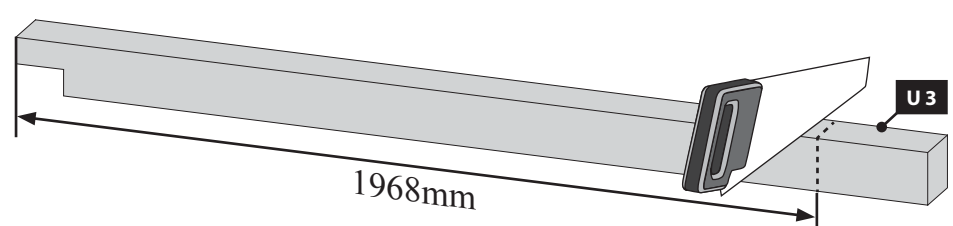

30c 2x

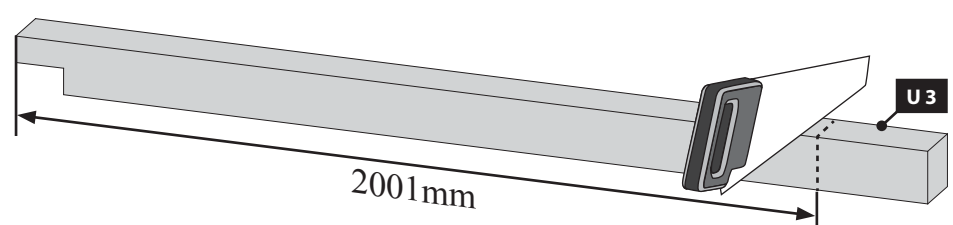

1x

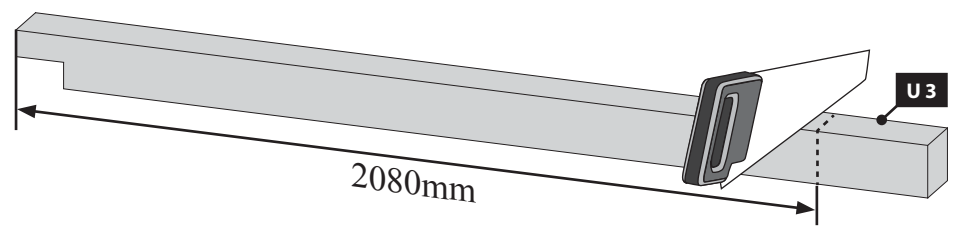

34C

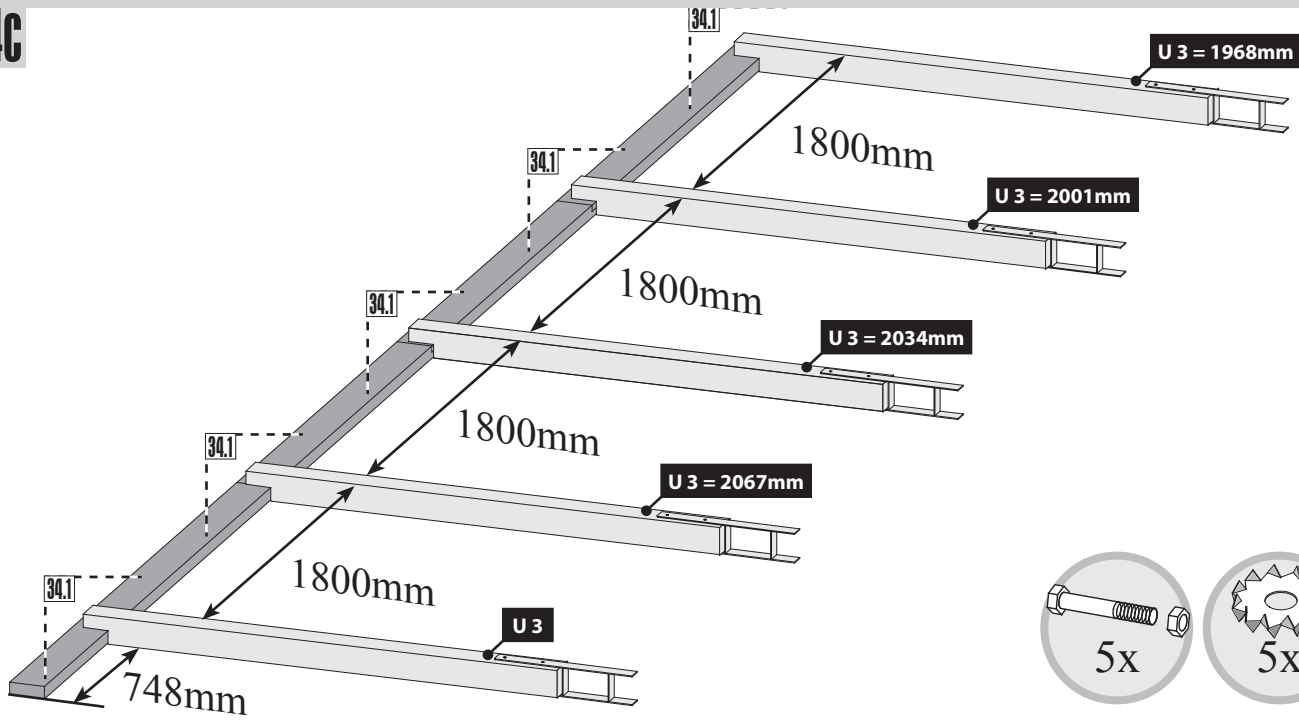

35C

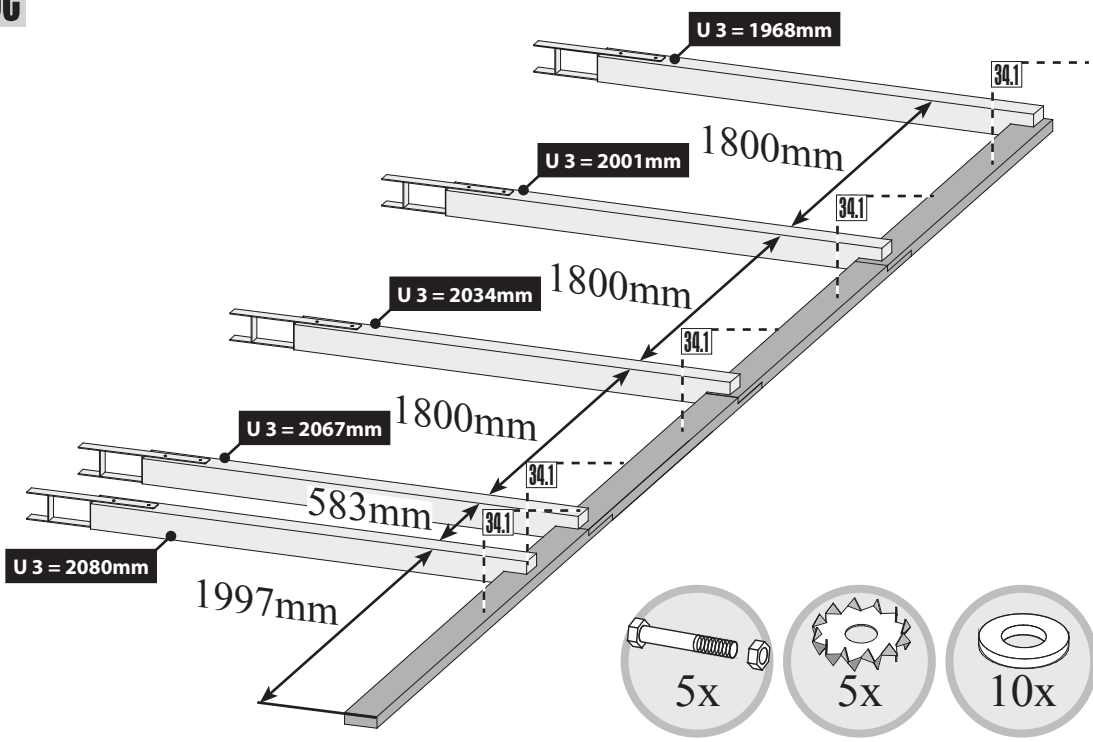

34.1

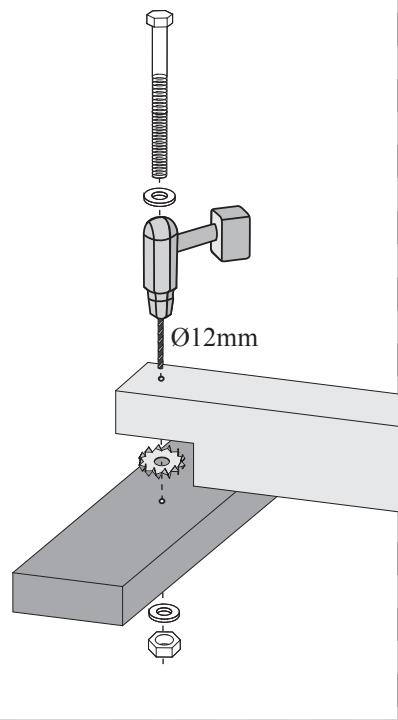

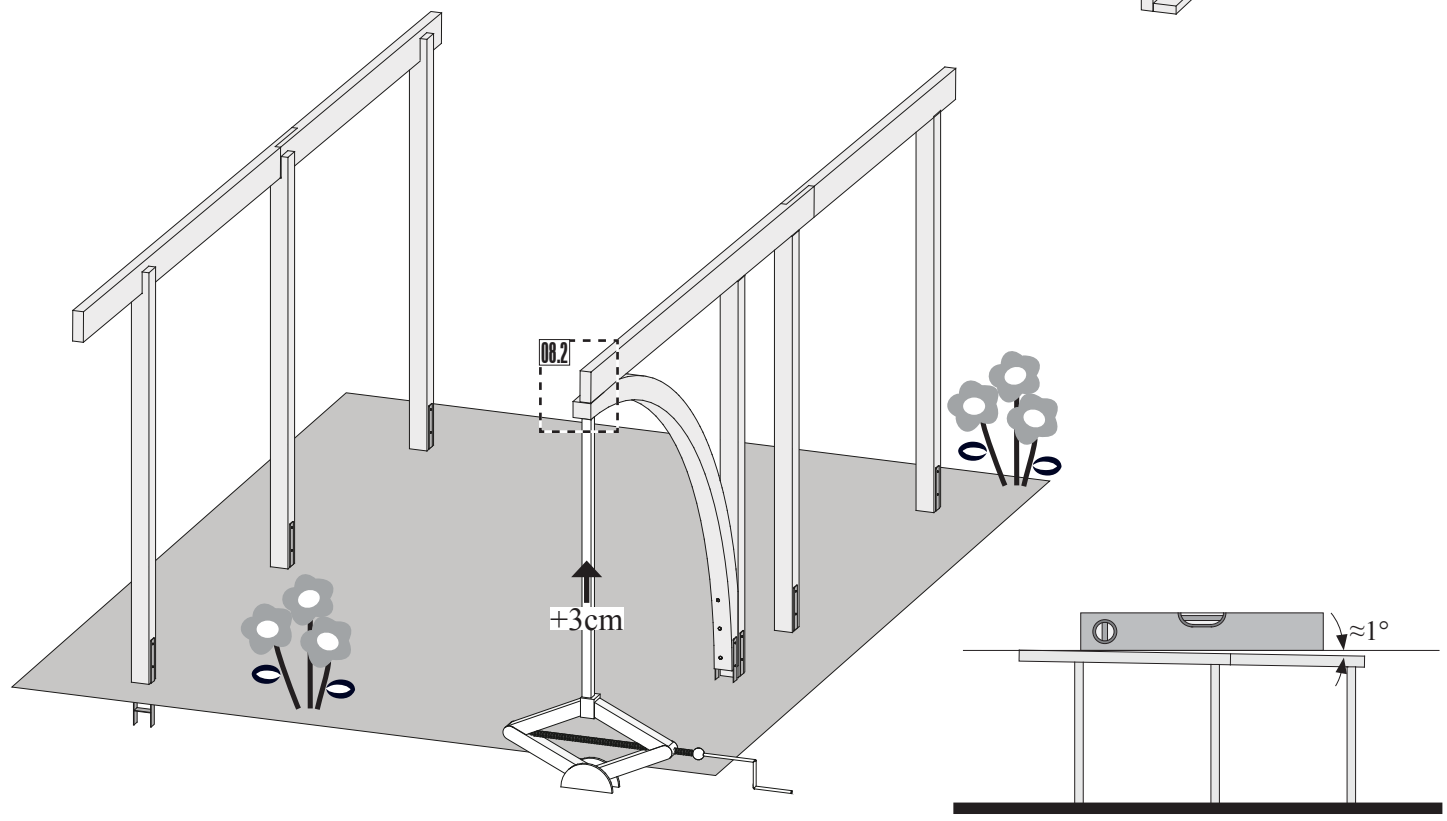
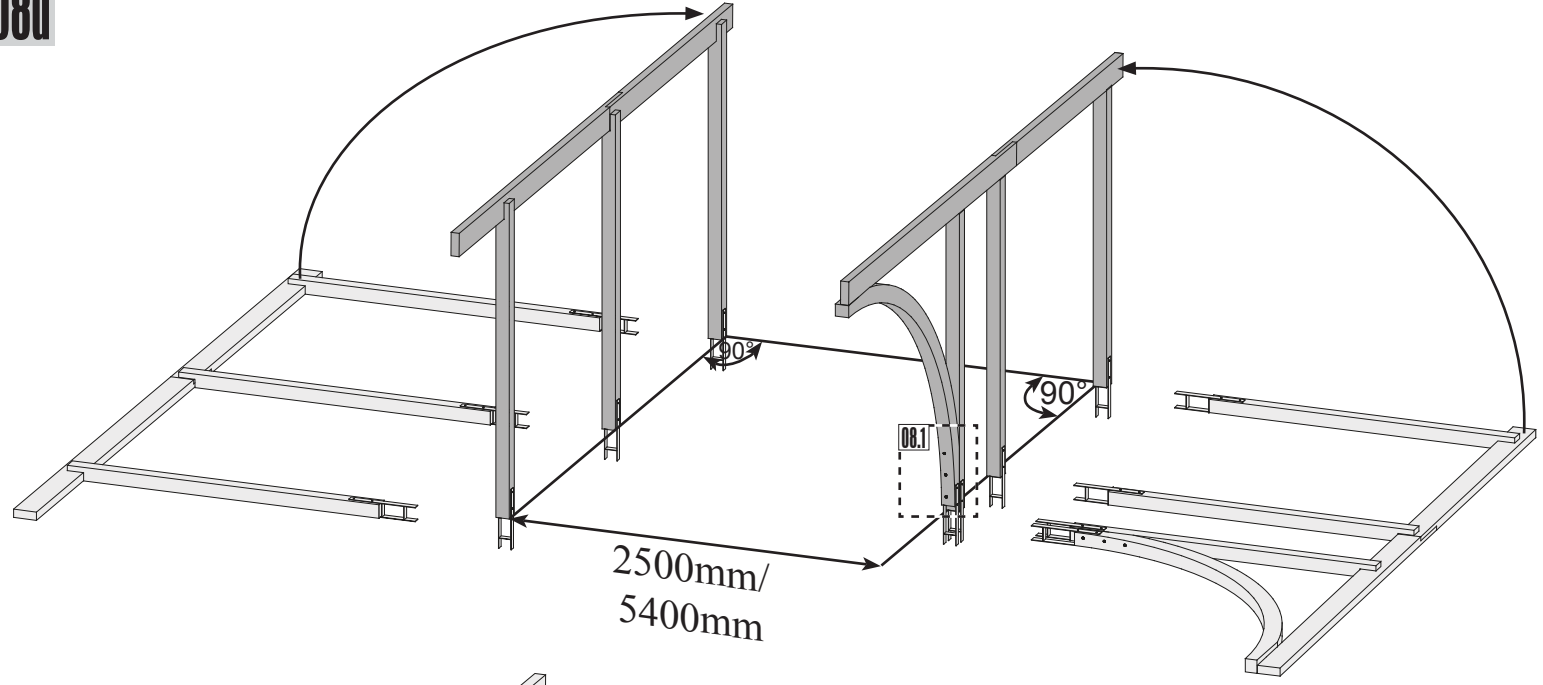

08.1

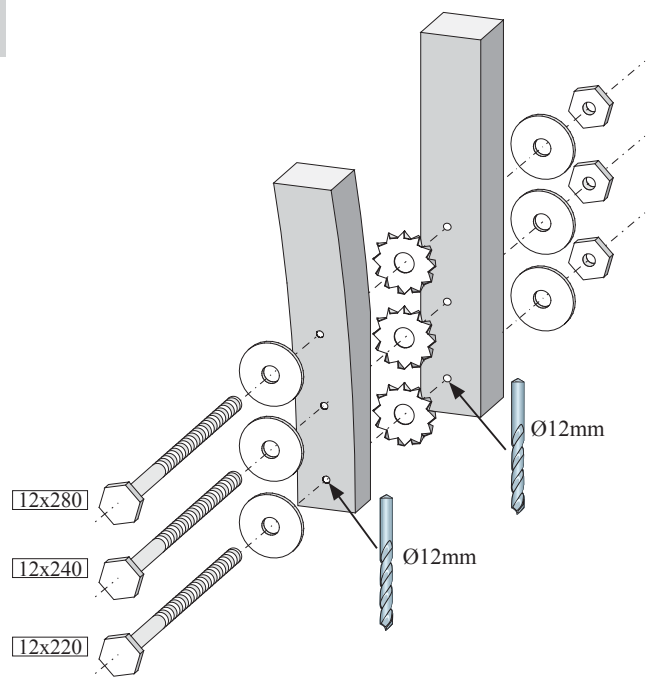

08.2

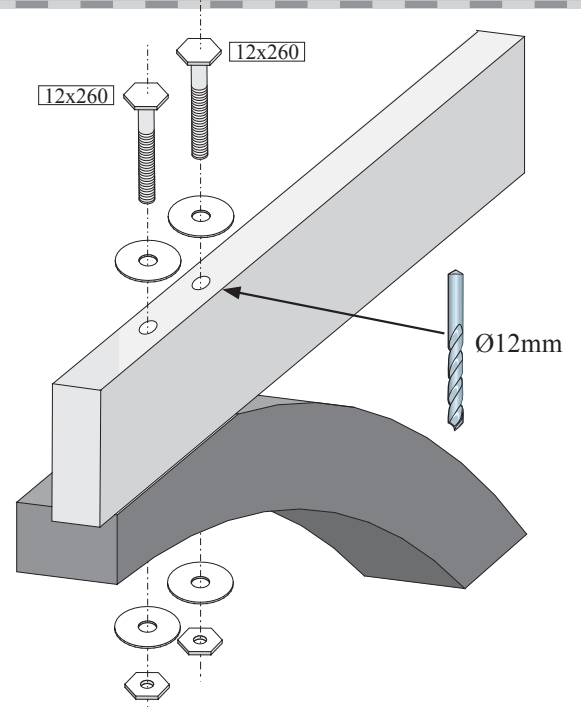

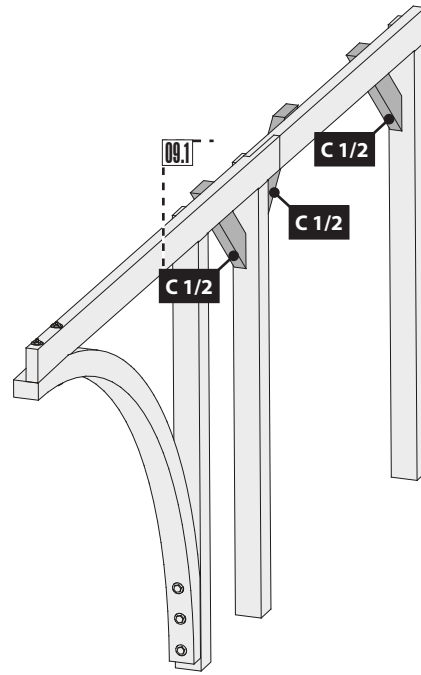
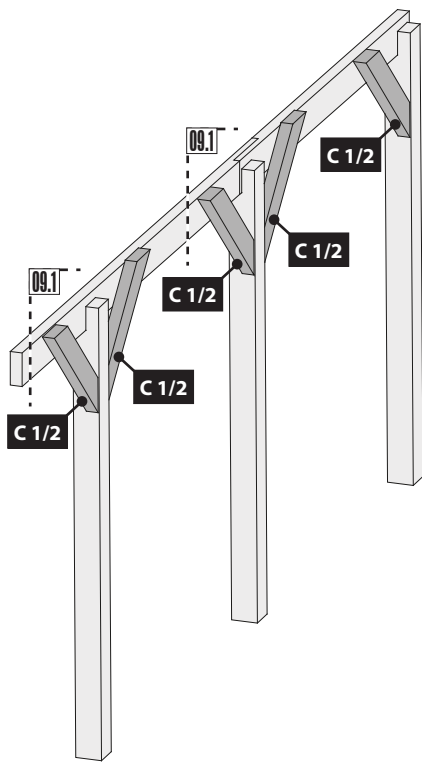

09.1

